



—  
your partner  
in sensor  
technology.

# + User Manual EE210

Humidity and Temperature Sensor  
for Demanding Climate Control



# Content

<b>1</b>	<b>General Information</b>	<b>3</b>
1.1	Explanation of Warning Notices and Symbols	3
1.2	Safety Instructions	4
1.2.1	General Safety Instructions	4
1.2.2	Intended Use	4
1.2.3	Mounting, Start-up and Operation	4
1.3	Environmental Aspects	5
1.4	ESD Protection	5
<b>2</b>	<b>Scope of Supply</b>	<b>6</b>
<b>3</b>	<b>Product Description</b>	<b>6</b>
3.1	General	6
3.2	Dimensions	7
3.3	Electrical Connection	8
3.3.1	Remote Probe PE210 for Type T3	10
3.3.2	Selection of the Output Signal Voltage or Current	11
3.4	Display	11
<b>4</b>	<b>Mounting and Installation</b>	<b>12</b>
4.1	General	12
4.2	Outdoor Installation with Radiation Shield	12
<b>5</b>	<b>Setup and Configuration</b>	<b>13</b>
5.1	Product Configuration	13
5.1.1	EE210 Configuration using HA011070	13
5.1.2	EE210 Configuration using legacy USB configuration adapter HA011066	14
5.2	PCS10 Product Configuration Software	14
5.3	RS485 Digital Interface with Modbus RTU Protocol	15
5.3.1	Hardware Bus Termination	15
5.3.2	Device Address	15
5.3.3	BACnet Protocol Settings	15
5.3.4	Modbus RTU Protocol Settings	16
5.4	Modbus Register Map	17
5.5	Modbus RTU Example	18
<b>6</b>	<b>Maintenance and Service</b>	<b>18</b>
6.1	Calibration and Adjustment	18
6.1.1	RH Calibration and Adjustment	19
6.1.2	T Calibration and Adjustment	19
6.1.3	Filter Cap Exchange	19
6.1.4	Display Change	19
6.1.5	Sensing Element Cleaning	20
6.2	Repairs	20
<b>7</b>	<b>Accessories</b>	<b>20</b>
<b>8</b>	<b>Technical Data</b>	<b>20</b>
<b>9</b>	<b>Conformity</b>	<b>23</b>
9.1	Declarations of Conformity	23
9.2	Electromagnetic Compatibility	23
9.3	FCC Part 15 Compliance Statement	23
9.4	ICES-003 Compliance Statement	23

# 1 General Information

This user manual serves for ensuring proper handling and optimal functioning of the device. The user manual shall be read before commissioning the equipment and it shall be provided to all staff involved in transport, installation, operation, maintenance and repair. E+E Elektronik Ges.m.b.H. does not accept warranty and liability claims neither upon this publication nor in case of improper treatment of the described products.

All information, technical data and diagrams included in this document are based on the information available at the time of writing. It may contain technical inaccuracies and typographical errors. The contents will be revised on a regular basis and changes will be implemented in subsequent versions. The described product(s) and the contents of this document may be changed or improved at any time without prior notice.

All rights reserved by E+E Elektronik Ges.m.b.H. No part of this document may be reproduced, published or publicly displayed in any form or by any means, nor may its contents be modified, translated, adapted, sold or disclosed to a third party without prior written permission of E+E Elektronik Ges.m.b.H.

## PLEASE NOTE

Find this document and further product information on our website at [www.epluse.com/ee210](http://www.epluse.com/ee210).

## 1.1 Explanation of Warning Notices and Symbols

### Safety precautions

Precautionary statements warn of hazards in handling the device and provide information on their prevention. The safety instruction labeling is classified by hazard severity and is divided into the following groups:

#### DANGER

**Danger** indicates hazards for persons. If the safety instruction marked in this way is not followed, the hazard will very likely result in severe injury or death.

#### WARNING

**Warning** indicates hazards for persons. If the safety instruction marked in this way is not followed, there is a risk of injury or death.

#### CAUTION

**Caution** indicates hazards for persons. If the safety instruction marked in this way is not followed, minor or moderate injuries may occur.

#### NOTICE

**Notice** signals danger to objects or data. If the notice is not observed, damage to property or data may occur.

### Informational notes

Informational notes provide important information which stands out due to its relevance.

#### INFO

The information symbol indicates tips on handling the device or provides additional information on it. The information is useful for reaching optimal performance of the device.

The title field can deviate from "INFO" depending on the context. For instance, it may also read "PLEASE NOTE".

## 1.2 Safety Instructions

### 1.2.1 General Safety Instructions

#### NOTICE

Improper handling of the device may result in its damage.

- The sensor and mainly the sensing head shall not be exposed to extreme mechanical stress.
- Do not apply the supply voltage to the RS485 data lines.
- The EE210 electronics is sensitive to electrostatic discharge (ESD), appropriate protective measures shall be taken when touching it.
- Use the EE210 only as intended and observe all technical specifications.

### 1.2.2 Intended Use

The EE210 sensor, which is available for wall or duct mounting, with a remote sensor and as an outdoor version, is intended for the highly accurate measurement of humidity and temperature in demanding air conditioning applications. The EE210 incorporates a state of the art E+E humidity and temperature sensing element. For use in special applications do not hesitate to contact E+E Elektronik or a local distributor.

#### WARNING

Non-compliance with the product documentation may cause safety risks for people and the entire measurement installation.

The manufacturer cannot be held responsible for damages as a result of incorrect handling, installation and maintenance of the device.

- Do not use EE210 in explosive atmosphere or for measurement in aggressive gases.
- This device is not appropriate for safety, emergency stop or other critical applications where device malfunction or failure could cause injury to human beings.
- The device may not be manipulated with tools other than specifically described in this manual.

#### NOTICE

Failing to follow the instructions in this user manual may lead to measurement inaccuracy and device failures.

- The EE210 may only be operated under the conditions described in this user manual and within the specification included in chapter 8 Technical Data.
- Unauthorized product modification leads to loss of all warranty claims. Modification may be accomplished only with an explicit permission of E+E Elektronik Ges.m.b.H.!
- For accurate measurement it is essential that the temperature of the probe and mainly of the sensing head is same as the temperature of the air to measure. Avoid mounting the sensor in a way which creates temperature gradients along the probe.
- The sensor must be operated with the filter cap on at all times. Do not touch the sensing element inside the sensing head.
- While replacing the filter cap (because of pollution for instance) against an original spare one please take very good care to not touch the sensors.

### 1.2.3 Mounting, Start-up and Operation

The EE210 has been produced under state of the art manufacturing conditions, has been thoroughly tested and has left the factory after fulfilling all safety criteria. The manufacturer has taken all precautions to ensure safe operation of the device. The user must ensure that the device is set up and installed in a way that does not impair its safe use. The user is responsible for observing all applicable local and international safety guidelines for safe installation and operation of the device. This user manual contains information and warnings that must be observed by the user in order to ensure safe operation.

**i PLEASE NOTE**

The manufacturer or his authorized agent can only be held liable in case of willful or gross negligence. In any case, the scope of liability is limited to the corresponding amount of the order issued to the manufacturer. The manufacturer assumes no liability for damages incurred due to failure to comply with the applicable regulations, operating instructions or the specified operating conditions. Consequential damage is excluded from liability.

**⚠ WARNING**

Non-compliance with the product documentation may cause accidents, personal injury or property damage.

- Mounting, installation, commissioning, start-up, operation and maintenance of the device may be performed by qualified staff only. Such staff must be authorized by the operator of the facility to carry out the mentioned activities.
- The qualified staff must have read and understood this user manual and must follow the instructions contained within. The manufacturer accepts no responsibility for non-compliance with instructions, recommendations and warnings.
- All process and electrical connections shall be thoroughly checked by authorized staff before putting the device into operation.
- Do not install or start-up a device supposed to be faulty. Make sure that such devices are not used accidentally by marking them clearly as faulty.
- A faulty device shall be removed from the process.
- A faulty device may only be investigated and possibly repaired by qualified, trained and authorized staff. If the fault cannot be fixed, the device shall be removed from the system.
- Service operations other than described in this user manual may only be performed by the manufacturer.

## 1.3 Environmental Aspects

**i PLEASE NOTE**

Products from E+E Elektronik Ges.m.b.H. are developed and manufactured in compliance with relevant environmental protection requirements. Please observe local regulations for the disposal of the device.



For disposal, the individual components of the device must be separated according to local recycling regulations. The electronics shall be disposed of correctly as electronics waste.

## 1.4 ESD Protection



The sensing elements and the electronics board are ESD (electrostatic discharge) sensitive components of the device and must be handled as such. Failure to do so may damage the device by electrostatic discharge when touching exposed sensitive components.

## 2 Scope of Supply

Model	EE210 Wall mount / Outdoor (Type T1 / T13)	EE210 Duct mount (Type T2)	EE210 with remote probe (Type T3) <sup>1)</sup>	PE210 Remote probe <sup>1)</sup> for Type T3	Additionally for all EE210 with RS485 interface
EE210 according to the ordering guide	✓	✓	✓	✓	
Cable gland	✓	✓	✓ (2pcs.)		✓
Mounting material	✓	✓	✓		
Mounting flange		✓		✓	
Inspection certificate according to DIN EN 10204-3.1	✓	✓	✓	✓	
Quick Guide - EE210 RS485 Setup					✓

1) PE210 is not included in the Scope of Supply of the EE210 Type T3

## 3 Product Description

### 3.1 General

The EE210 humidity (RH) and temperature (T) sensor has been developed to fulfil the highest requirements in demanding climate control applications. In addition to accurately measuring RH and T, the EE210 calculates various RH-related parameters such as dew point temperature, absolute humidity and mixing ratio.

The EE210 is particularly suitable for use in dirty or aggressive environments. This is ensured by the encapsulated measuring electronics inside the sensor and the long-term stable E+E sensing element with the proprietary coating.

All measured and calculated values are available at the BACnet MS/TP or Modbus RTU interface, two of them at the analogue voltage or current outputs. With the optional display, up to three values can be shown simultaneously.

The EE210 is available for wall or duct mounting, with remote sensor and as an outdoor version. The IP65 / NEMA 4X enclosure ensures excellent protection against dirt and condensation.

With an optional USB configuration adapter, the RS485 interface parameters and output scaling can be set, an offset or 2-point adjustment for RH and T can be carried out and the display layout can be changed.

### 3.2 Dimensions

Values in mm (inch)

#### Type T1 (wall mount)

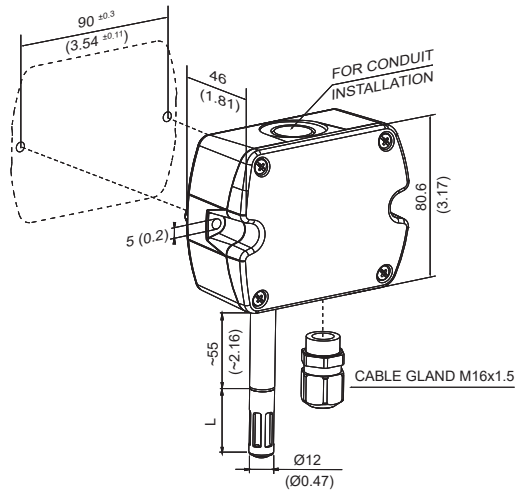

#### Type T2 (duct mount)

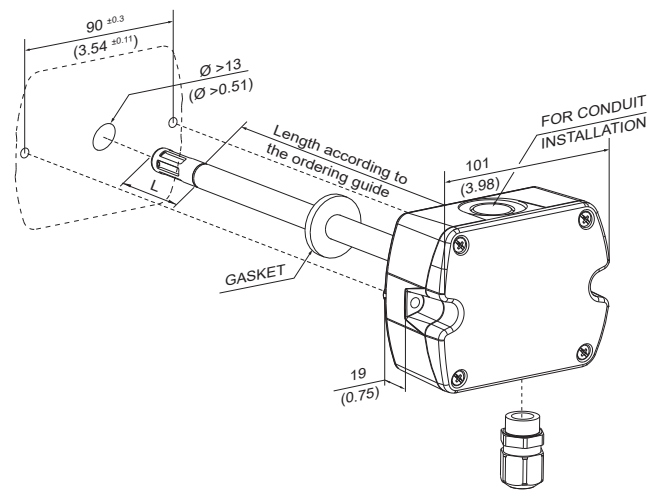

L = filter cap length	mm (inch)
Membrane	34 (1.4)
Stainless steel	33 (1.3)
Metal grid	33 (1.3)

#### Type T3 (remote probe)

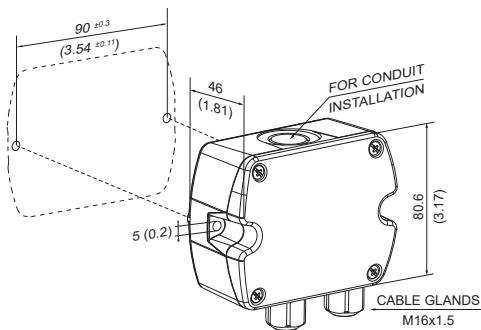

#### PE210

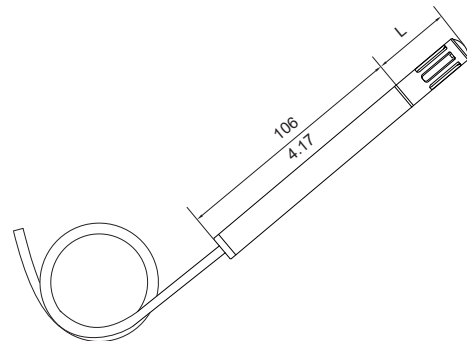

#### Type T13 (outdoor)

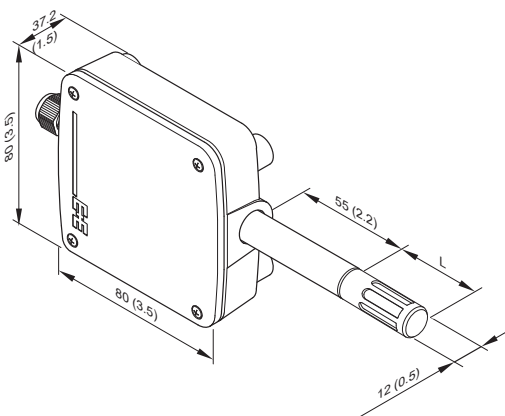

#### Mounting flange

in the scope of supply for type T2 and T3

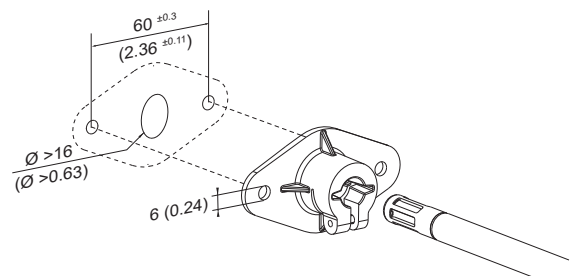

**Radiation shield HA010501 for type T13 (outdoor)**  
needs to be ordered separately

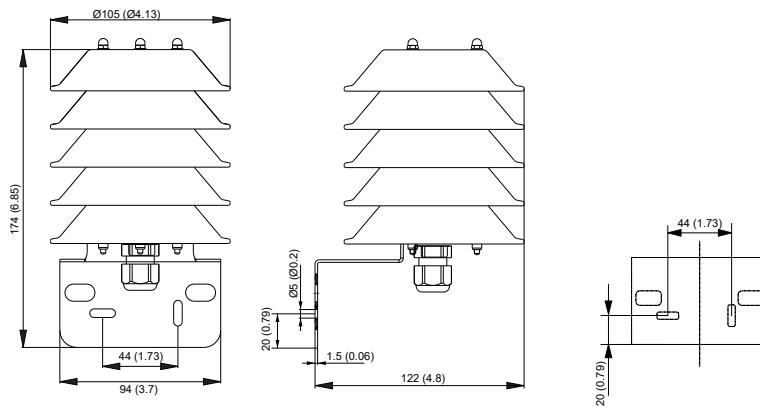

### 3.3 Electrical Connection

The EE210 features screw terminals for connecting the power supply and the outputs.

**EE210 with cable gland:** Use a matching wrench to install the M16 cable gland (in the scope of supply) onto the EE210 enclosure.

**EE210 with conduit connection** for the North American market: Use a flat screwdriver to knock open the blind, carefully, in order to avoid damaging the electronics inside the enclosure. The conduit adapter is not included in the scope of supply. The M16x1.5 opening for the cable gland shall be tightly closed using the blind plug included in the scope of supply.

#### NOTICE

Ensure that the cable glands are closed tightly for the power supply and output cable. This is necessary for assuring the IP rating of the enclosure according to EE210 specification, as well as for stress relief at the screw terminals on the EE210 board.

#### ⚠ WARNING

Incorrect installation, wiring or power supply may cause overheating and therefore personal injuries or damage to property.

It is essential that the cables are not under voltage during installation. No voltage must be applied when the product is connected or disconnected. For correct cabling of the device, always observe the presented wiring diagram for the product version used.

The manufacturer cannot be held responsible for personal injuries or damage to property as a result of incorrect handling, installation, wiring, power supply and maintenance of the device.

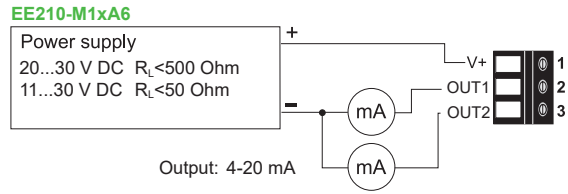
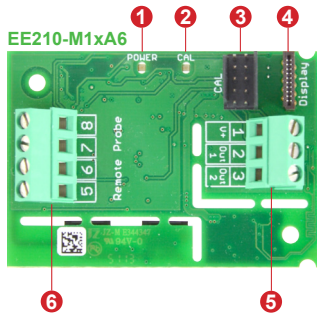

**i PLEASE NOTE**

The EE210-M1xA6 (4...20 mA, 2-wire) with display only operates correctly if both outputs are connected.

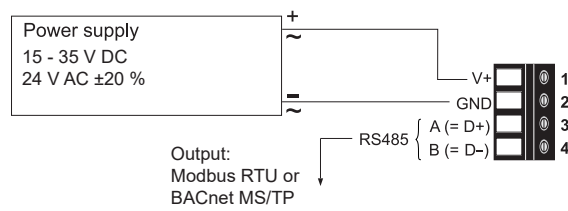
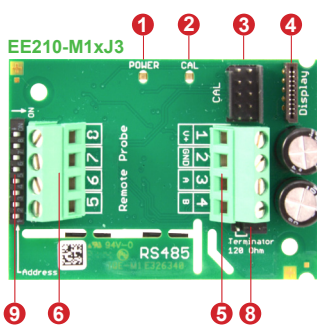
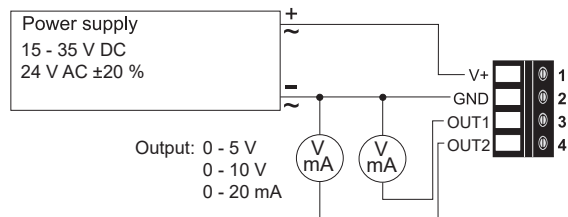
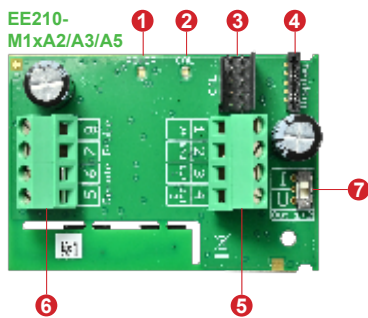
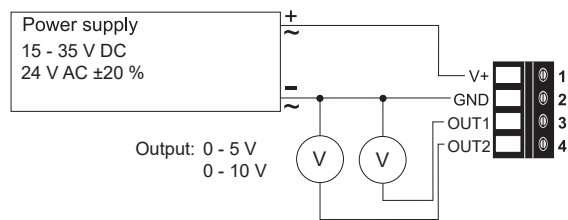
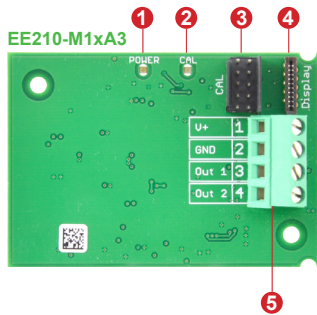

Fig. 1 EE210 connection options

No.	Function
①	<b>Green LED</b> Information during operation
	On            normal operation
	Flashing    the main board does not recognize the probe's measurement electronics
	Off            no power supply or main board failure
②	<b>Blue LED</b> Information during setup with the optional USB-C configuration stick HA011070 and the PCS10 Product Configuration Software
	On            USB connection to PC, no communication with PCS10
	Flashing    communication with PCS10 in progress
	Off            no USB connection to PC
③	Configuration connector, refer to 5 Setup and Configuration for detailed information
④	FFC cable socket for the display
⑤	Screw terminals for power supply and outputs
⑥	Screw terminals, only connect the remote probe (refer to chapter 3.3.1 Remote Probe PE210 for Type T3)
⑦	Output signal (I / U) selection (refer to chapter 3.3.2 Selection of the Output Signal Voltage or Current)
⑧	Bus termination resistor 120 Ω (jumper)
⑨	Address DIP switch for RS485 interface

Tab. 1 Parts of the EE210 electronics board types

### 3.3.1 Remote Probe PE210 for Type T3

The PE210 (remote probe for EE210-M1T3x) shall be ordered and it is supplied as separate item. PE210 is to be connected to the EE210 by the user.

#### Procedure

1. First install the cable gland (included in the EE210 scope of supply) on the EE210 enclosure.
2. Before connecting the probe, disconnect the EE210 power supply.
3. Feed the PE210 cable through the cable gland and connect it to the screw terminals according to the connection diagram below.

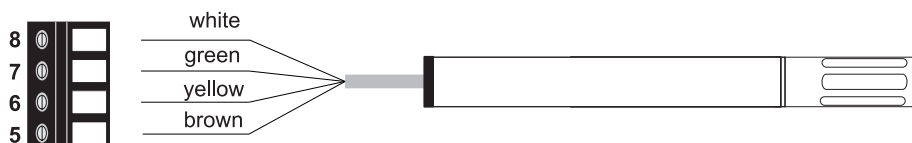

Fig. 2 Connection diagram of the PE210

#### **i** PLEASE NOTE

PE210 is an intelligent probe with digital output which is interchangeable.

If the sensor or its cable is damaged or a longer cable is needed, please order a replacement sensor in accordance with the EE210 datasheet.

The replacement probe shall be installed as described above.

#### NOTICE

Ensure that the cable glands are closed tightly for the power supply and output cable. This is necessary for assuring the IP rating of the enclosure according to EE210 specification, as well as for stress relief at the screw terminals on the EE210 board.

### 3.3.2 Selection of the Output Signal Voltage or Current

The factory setup of the output signal and scaling corresponds to the specified order code.

For EE210 types ordered with either:

- Remote probe with 3 wire output (A2/A3 or A5)
- Display with backlight (D2)
- 0 - 20 mA output (A5, 3-wire)

The output signal voltage (U) or current 3-wire (I) can be selected with the DIP switch on the main electronics board (refer to 3.3 Connection Diagram - EE210-M1xA2/3/5). This does not affect the scaling of the outputs, which can be changed using the PCS10 Product Configuration Software and the optional USB-C configuration stick HA011070.

#### Examples

**Factory setup: voltage output 0 - 5 V or 0 - 10 V corresponds to 0...100 %RH.**

After switching from U to I: current output 4 - 20 mA (3-wire) corresponds to 0...100 %RH.

A change of the current output range for instance to 0 - 20 mA can be made subsequently with the PCS10 Product Configuration Software and the optional USB-C configuration stick HA011070.

**Factory setup: current output 0 - 20 mA or 4 - 20 mA (3-wire) corresponds to -10...+50 °C.**

After switching from I to U: voltage output 0 - 10 V corresponds to -10...+50 °C.

A change of the voltage output range for instance to 0 - 5 V can be made subsequently with the PCS10 Product Configuration Software and the optional USB-C configuration stick HA011070.

## 3.4 Display



Fig. 3 EE210 display setup

#### Factory setup

The display shows the two parameters selected for output 1 and output 2 (according to the ordering code). For the Modbus version the display shows RH and T.

#### User setup

The user can change the display layout to 1, 2 or 3 lines and select the parameters to be displayed by using PCS10 Product Configuration Software (free download from [www.epluse.com/pcs10](http://www.epluse.com/pcs10)) and USB-C configuration stick HA011070 (not included in the scope of supply).

#### **i PLEASE NOTE**

The EE210-M1xA6 (4...20 mA, 2-wire) with display only operates correctly if both outputs are connected.

# 4 Mounting and Installation

## 4.1 General

For mounting, the cable gland (in the scope of supply) onto the EE210 enclosure use a matching wrench.

When using EE210 with conduit connection for the North American market use a flat screwdriver to knock open the blind at the top of the enclosure, carefully. Take good care to avoid damaging the electronics inside the enclosure. The conduit adapter is not included in the scope of supply. The M16x1.5 opening for the cable gland shall be tightly closed using the blind plug included in the scope of supply (see also chapter 3.2 Dimensions).

For best measurement results, the EE210

- must be installed in an environment where the medium to be measured flows sufficiently around the probe.
- shall not be placed near influencing objects such as heating radiators or fan heaters. See also mounting positions of the radiation shield for Type T13.
- self heating effects are compensated. For Type T13 the accuracies are valid at 24 V DC and 250  $\Omega$  load resistance for A6 versions.

## 4.2 Outdoor Installation with Radiation Shield

EE210-T13xxx (outdoor type) can be installed with a radiation shield (order code HA010501). Choose an appropriate place to mount the sensor observing the general mounting instructions and recommended mounting positions of the radiation shield.

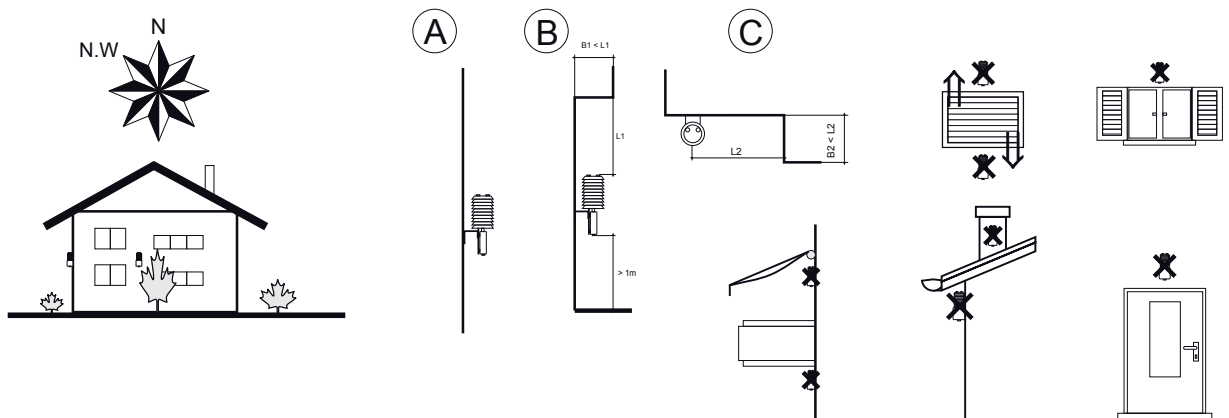

Fig. 4 Mounting position

Follow these steps to mount the EE210 in the radiation shield (see Fig. 5):

4. Drill the holes according to the mounting template (see chapter 3.2 Dimensions) and mount the radiation shield in a vertical position using the screws and dowels (included in the scope of supply).
5. Fix the EE210 on the mounting plate with four M4x10 screws (included in the scope of supply).
6. Insert the EE210 in the radiation shield and fix the mounting plate with two M4x10 screws on the radiation shield (included in the scope of supply).
7. Connect the power supply and the analogue outputs. Close the cover of the EE210 sensor.

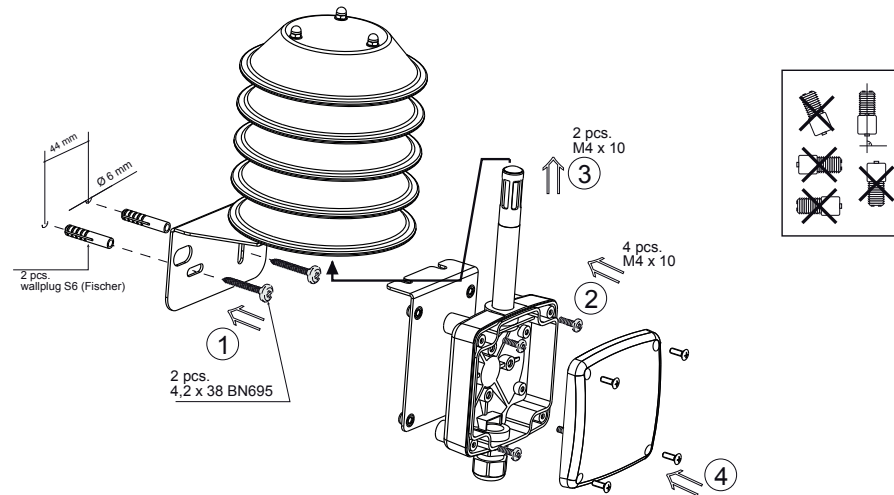

Fig. 5 Mounting instruction

## 5 Setup and Configuration

The EE210 is ready to use and does not require any configuration by the user. The factory setup of EE210 corresponds to the specified order code. Please refer to the datasheet at [www.epluse.com/ee210](http://www.epluse.com/ee210). If needed, the user can change the factory setup with the help of the free PCS10 Product Configuration Software and the USB-C configuration stick (HA011070).

The user can change the scaling and the analogue output signal, the digital settings, perform RH and T adjustment and change display layout.

### 5.1 Product Configuration

#### 5.1.1 EE210 Configuration using HA011070

for all types (analogue, digital)

#### NOTICE

The USB-C configuration stick HA011070 galvanically isolates the USB interface of the PC from the supply voltage of the EE210. When using the USB-C configuration stick the EE210 needs external supply.

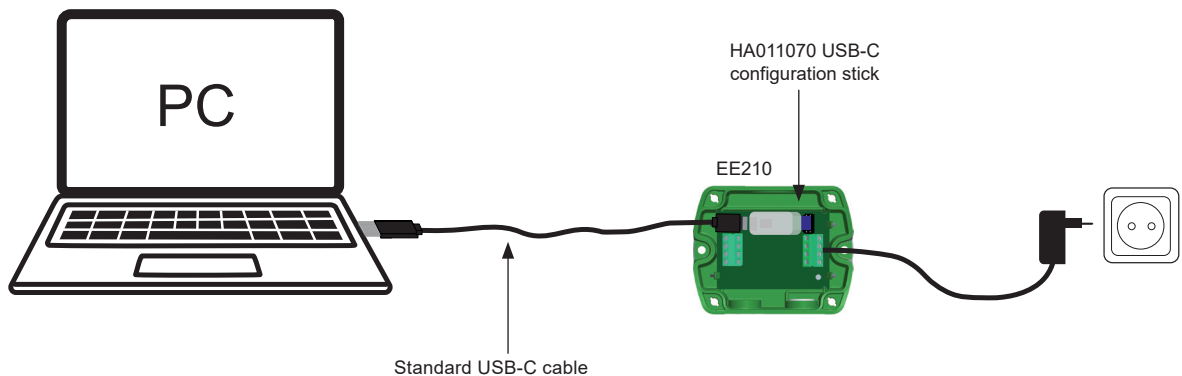

Fig. 6 EE210 configuration using the HA011070 USB-C configuration stick

### 5.1.2 EE210 Configuration using legacy USB configuration adapter HA011066

(not intended for new designs)

#### EE210-M1xA2/A3/A5 types (3-wire)

##### NOTICE

The EE210 may not be connected to any additional power supply when using the USB configuration adapter HA011066.

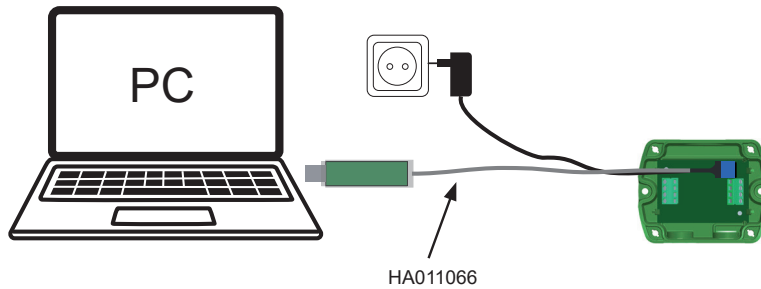

Fig. 7 EE210-M1xA2/A3/A5 types (3-wire) connected to a PC running PCS10

#### EE210-M1xA6 type (2-wire)

##### NOTICE

The EE210 must be directly supplied on the electronics board (do not use the power supply from the adapter) when using the configuration adapter HA011066.

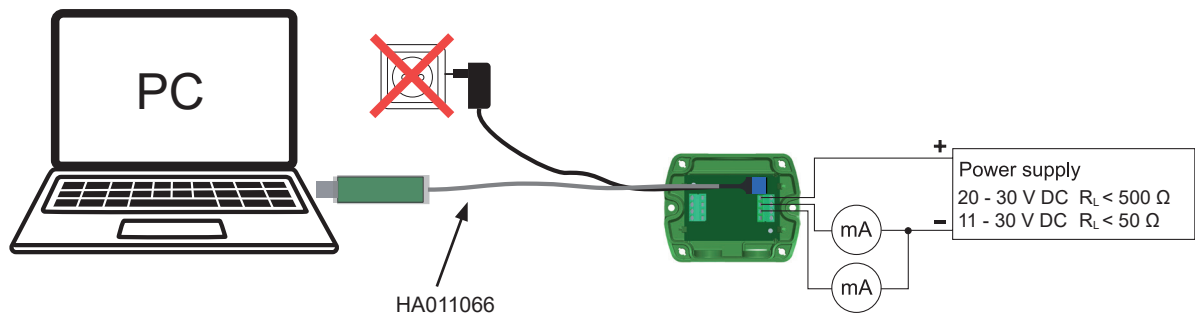

Fig. 8 EE210-M1xA6 type (2-wire) connected to a PC running PCS10

## 5.2 PCS10 Product Configuration Software

To use the software for changes in settings, please proceed as follows:

1. Download the PCS10 Product Configuration Software from [www.epluse.com/pcs10](http://www.epluse.com/pcs10) and install it on the PC.
2. Connect the EE210 to the PC using the configuration adapter.
3. Start the PCS10 software.
4. Follow the instructions on the PCS10 opening page for scanning the ports and identifying the connected device
5. Click on the desired setup mode from the main PCS10 menu on the left. Follow the online instructions of the PCS10 which are displayed when clicking the "Tutorial" button.
6. Changes are uploaded to the sensor by pressing the "Sync" button.

## 5.3 RS485 Digital Interface with Modbus RTU Protocol

### 5.3.1 Hardware Bus Termination

For bus termination EE210 features an internal 120 Ω resistor which can be activated using the jumper on the electronics board (refer to chapter 3.3 Electrical Connection for details).

- Jumper not mounted (right position = factory setup): bus is not terminated



- Jumper mounted (left position): bus is terminated



### 5.3.2 Device Address

#### Address Switch



#### Address setting via PCS10 Product Configuration Software

All DIP switches at position 0 → address has to be set via PCS10

**Modbus** (slave device): factory setting 242 (permitted values: 1...247).

**BACnet** (master device): factory setting 1 (permitted values: 0...127).

*Example: Address is set via configuration software = factory setting.*

#### Address Switch



#### Address setting via DIP switch

**Modbus** (slave device): Setting the DIP switches to any other address than 0, overrules the Modbus address set via PCS10 (permitted values: 1...247).

*Example: Address set to 11 (= 0000 1011 binary).*

### 5.3.3 BACnet Protocol Settings

	Factory settings	User selectable values (via PCS10)
Baud rate	As per type number ordered	9 600, 19 200, 38 400, 57 600, 76 800, 115 200
Data bits	8	8
Parity	None	None
Stop bits	1	1
BACnet address	1	0...127

Tab. 2 BACnet protocol settings

#### **i PLEASE NOTE**

The recommended settings for multiple devices in a BACnet MS/TP network are 38 400, 8, none, 1.

The EE210 PICS (Product Implementation Conformance Statement) is available on the E+E website at [www.epluse.com/ee210](http://www.epluse.com/ee210).

BACnet address and baud rate can be set via:

- PCS10 Product Configuration Software and the USB-C configuration stick HA011070.
- BACnet protocol, see the PICS.

### 5.3.4 Modbus RTU Protocol Settings

	Factory settings	Selectable values (via PCS10)
Baud rate	As per type number ordered	9 600, 19 200, 38 400, 57 600, 76 800, 115 200
Data bits	8	8
Parity	Even	None, odd, even
Stop bits	1	1, 2
Modbus address	242	1...247

Tab. 3 Modbus RTU protocol settings

#### **i** PLEASE NOTE

- The recommended settings for multiple devices in a Modbus RTU network are 9600, 8, even, 1.
- The EE210 represents 1 unit load on an RS485 network.

Device address, baud rate, parity and stop bits can be set via:

- The PCS10, Product Configuration Software and the USB-C configuration stick HA011070. The PCS10 can be downloaded free of charge from [www.epluse.com/pcs10](http://www.epluse.com/pcs10).
- Modbus protocol in the register 1 (0x00) and 2 (0x01). See Application Note Modbus AN0103 (available at [www.epluse.com/ee210](http://www.epluse.com/ee210)).

The serial number as ASCII-code is located in read-only registers 1 - 8 (0x00 - 0x07).

The firmware version is located in read-only register 9 (0x08) (bit 15...8 = major release; bit 7...0 = minor release).

The sensor name as ASCII-code is located in read-only registers 10 - 17 (0x09 - 0x10).

#### NOTICE

When reading information that spans multiple registers, it is always necessary to read all registers, even if the desired information requires less.

#### NOTICE

For obtaining the correct floating point values, both registers have to be read within the same reading cycle. The measured value can change between two Modbus requests, exponent and mantissa may get inconsistent then.

#### **i** INFO

The Modbus function codes mentioned throughout this document shall be used as described in the MODBUS APPLICATION PROTOCOL SPECIFICATION V1.1b3, chapter 6: [www.modbus.org/docs/Modbus\\_Application\\_Protocol\\_V1\\_1b3.pdf](http://www.modbus.org/docs/Modbus_Application_Protocol_V1_1b3.pdf)

#### Communication settings (INT16)

Parameter	Register number <sup>1)</sup> [Dec]	Register address <sup>2)</sup> [Hex]	Size <sup>3)</sup>
Write register: function code 0x06			
Modbus address <sup>4)5)</sup>	1	00	1
Modbus protocol settings <sup>4)</sup>	2	01	1

**Device information (INT16)**

Parameter	Register number <sup>1)</sup> [Dec]	Register address <sup>2)</sup> [Hex]	Size <sup>3)</sup>
Read register: function code 0x03 / 0x04			
Serial number (as ASCII)	1	00	8
Firmware version	9	08	1
Sensor name (as ASCII)	10	09	8

1) Register number (decimal) starts from 1.

2) Register address (hexadecimal) starts from 0.

3) Number of registers.

4) For Modbus address and protocol settings see Application Note Modbus AN0103 (available at [www.epluse.com/ee210](http://www.epluse.com/ee210)).

5) If the address is set via DIP-switch the response will be NAK.

Tab. 4 EE210 registers for device setup

## 5.4 Modbus Register Map

The measurement data is saved as 32 bit floating point values (data type FLOAT32) and as 16 bit signed integer values (data type INT16).

**FLOAT32**

Parameter	Unit <sup>1)</sup>	Register number <sup>2)</sup> [DEC]	Register address <sup>3)</sup> [HEX]
Read register: function code 0x03 / 0x04			
Temperature	°C, °F	26	19
Relative humidity	%	28	1B
Water vapour partial pressure	mbar, psi	30	1D
Dew point temperature	°C, °F	32	1F
Wet bulb temperature	°C, °F	34	21
Absolute humidity	g/m <sup>3</sup> , gr/ft <sup>3</sup>	36	23
Mixing ratio	g/kg, gr/lb	38	25
Specific enthalpy	kJ/kg,BTU/lb	40	27
Frost point temperature	°C, °F	42	29

**INT16**

Parameter	Unit <sup>1)</sup>	Scale <sup>4)</sup>	Register number <sup>2)</sup> [DEC]	Register address <sup>3)</sup> [HEX]
Read register: function code 0x03 / 0x04				
Temperature	°C, °F	100	301	12C
Relative humidity	%	100	302	12D
Water vapour partial pressure	mbar, psi	100	303	12E
Dew point temperature	°C, °F	100	304	12F
Wet bulb temperature	°C, °F	100	305	130
Absolute humidity	g/m <sup>3</sup> , gr/ft <sup>3</sup>	100	306	131
Mixing ratio	g/kg, gr/lb	100	307	132
Specific enthalpy	kJ/kg,BTU/lb	100	308	133
Frost point temperature	°C, °F	100	309	134

1) The choice of measurement units (metric or non-metric) must be done according to the ordering guide, see EE210 datasheet. Switching from metric to non-metric or vice versa by using the PCS10 is not possible.

2) Register number (decimal) starts from 1

3) Register address (hexadecimal) starts from 0

4) Examples: For scale 100, the reading of 2550 means a value of 25.5. For scale 50, the reading of 2550 means a value of 51.

Tab. 5 EE210 FLOAT32 and INT16 measured data registers

## 5.5 Modbus RTU Example

The EE210's Modbus address is 242 [0xF2].

Please refer to

- MODBUS APPLICATION PROTOCOL SPECIFICATION V1.1b3, chapter 6: [www.modbus.org/docs/Modbus\\_Application\\_Protocol\\_V1\\_1b3.pdf](http://www.modbus.org/docs/Modbus_Application_Protocol_V1_1b3.pdf)
- E+E Application Note Modbus AN0103 (available at [www.epluse.com/ee210](http://www.epluse.com/ee210))

Read the temperature (FLOAT32) T = 24.270019 °C from register address 0x19:

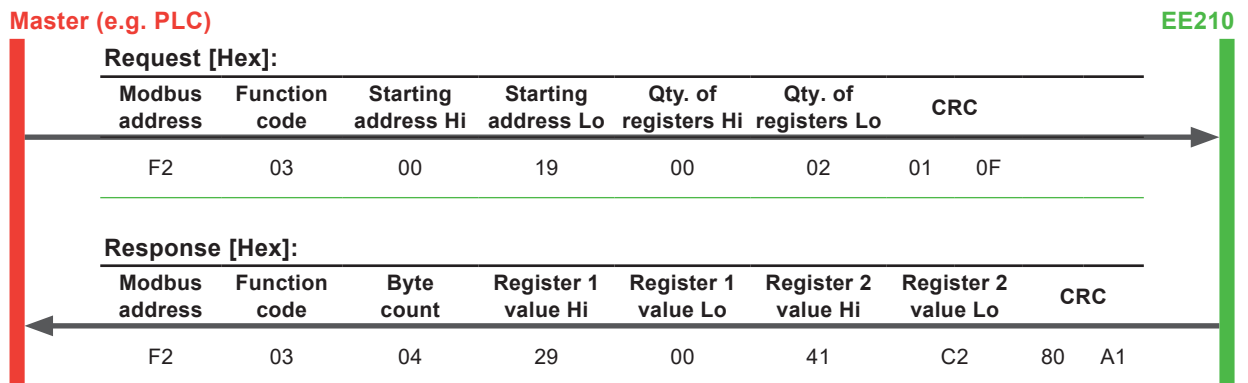

Tab. 6 Example temperature query

### Decoding of floating point values:

Floating point values are stored according to IEEE754. The byte pairs 1, 2 and 3, 4 are transformed as follows (numbers taken from T reading Modbus request/response example above):

Modbus response [Hex]			
Byte 3	Byte 4	Byte 1	Byte 2
29	00	41	C2
MMMMMMMM	MMMMMMMM	SEEEEEEE	EMMMMMMM

Tab. 7 Modbus response

IEEE754			
Byte 1	Byte 2	Byte 3	Byte 4
41	C2	29	00
0100 0001	1100 0010	0010 1001	0000 0000
SEEE EEEE	EMMM MMMM	MMMM MMMM	MMMM MMMM
Decimal value: 24.270019			

Tab. 8 Data representation according to IEEE754

# 6 Maintenance and Service

## 6.1 Calibration and Adjustment

Depending on the application and the requirements of certain industries, there might arise the need for periodical humidity calibration (comparison with a reference) or adjustment (bringing the device in line with a reference).

### Definitions

- **Calibration** documents the accuracy of a measurement device. The device under test (specimen) is compared with the reference and the deviations are documented in a calibration certificate. During the calibration, the specimen is not changed or improved in any way.
- **Adjustment** improves the measurement accuracy of a device. The specimen is compared with the reference and brought in line with it. An adjustment can be followed by a calibration which documents the accuracy of the adjusted specimen.

### 6.1.1 RH Calibration and Adjustment

#### Calibration and adjustment at E+E Elektronik

Calibration and/or adjustment can be performed in the E+E Elektronik calibration laboratory.

For information on the E+E capabilities in ISO or accredited calibration please refer to [www.eplusecal.com](http://www.eplusecal.com).

#### Calibration and adjustment by the user

Depending on the level of accuracy required, the humidity reference can be:

- Humor 20 Humidity Calibrator, please refer to [www.epluse.com](http://www.epluse.com).
- Omniport 40 handheld device, please refer to [www.epluse.com/omniport40](http://www.epluse.com/omniport40).
- Calibrated salt solutions, please refer to [www.epluse.com/ee210](http://www.epluse.com/ee210).

### 6.1.2 T Calibration and Adjustment

Due to the outstanding protection of the temperature sensing element integrated in the E+E RH/T sensing element, a drift of the T measurement is rather unlikely. If adjustment seems necessary, although the user can perform an offset or 2-point T adjustment with USB configuration adapter and PCS10 against a reference of his choice, it is highly recommended to return the device to the manufacturer for this. The reasons rest on the difficulty of an accurate T calibration in the air. The calibration shall take into account the self-heating of EE210 with closed enclosure, in its real mounting position and in continuous operation, the impact of the output current and of the probe orientation to the self-heating, as well as the cooling effect of the air circulation in a climate chamber possibly used for calibration.

### 6.1.3 Filter Cap Exchange

In a dusty, polluted environment it might be necessary to replace the filter cap once in a while. In most of the cases, a clogged filter shows visible contamination or dirt. Longer response time of the measurement also indicates a clogged filter cap. In such cases, replace the filter by a new, original one, refer to the “Accessories” datasheet.

#### Procedure:

1. Turn the filter cap counter-clockwise for removing it.
2. Install the new filter cap fingertight by turning it clockwise.

### 6.1.4 Display Change

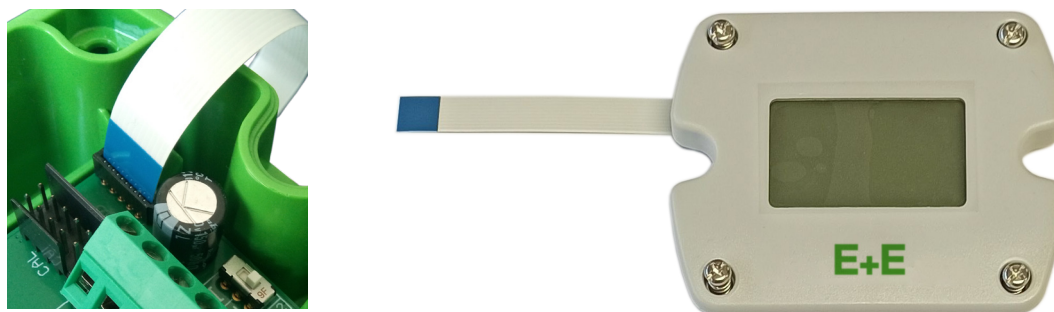

Fig. 9 Display and FFC cable connection on the EE210 electronics board

When connecting the display's FFC cable to the EE210 electronics board, please observe the correct orientation. The blue cable stiffener needs to be on the left side as shown in Fig. 9.

**NOTICE**

Disconnecting or connecting the display while the EE210 is powered may cause damages to EE210 and to the display.

Always switch off the EE210 before exchanging the display.

**6.1.5 Sensing Element Cleaning**

For cleaning instructions please refer to [www.epluse.com/ee210](http://www.epluse.com/ee210).

**6.2 Repairs**

Repairs may be carried out by the manufacturer only. The attempt of unauthorized repair excludes any warranty claims.

**7 Accessories**

For further information please refer to the [Accessories](#) datasheet.

Accessories	Code
USB-C configuration stick	HA011070
PCS10 Product configuration software (Free download: <a href="http://www.epluse.com/pcs10">www.epluse.com/pcs10</a> )	PCS10
Radiation shield for EE210 Outdoor (Type T13)	HA010501
Power supply adapter	V03
Protection cap for Ø12 mm probe	HA010783

**8 Technical Data****Measurands****Relative humidity (RH)**

Measuring range	0...100 % RH
<b>Accuracy<sup>1)</sup></b> incl. hysteresis, non-linearity and repeatability	
<b>Type T1, T2</b>	
-15...+40 °C (+5...+104 °F), ≤90 %RH	±(1.3 + 0.003*measured value) %RH
-15...+40 °C (+5...+104 °F), >90 %RH	±2.3 %RH
-40...+60 °C (-40...+140 °F)	±(1.5 + 0.015*measured value) %RH
<b>Type T3</b>	
@ 20 °C (68 °F)	±2.5 %RH
<b>Type T13</b>	
-15...+40 °C (+5...+104 °F), ≤90 %RH	±(1.6 + 0.005*measured value) %RH
-15...+40 °C (+5...+104 °F), ≥90 %RH	±3 %RH
-40...+60 °C (-40...+140 °F)	±(2.3 + 0.008*measured value) %RH

1) Traceable to international standards, administrated by NIST, PTB, BEV,...

The accuracy statement includes the uncertainty of the factory calibration with an enhancement factor k=2 (2-times standard deviation).  
The accuracy was calculated in accordance with EA-4/02 and with regard to GUM (Guide to the Expression of Uncertainty in Measurement).  
For Type T13: @ 24 V DC and RL=250 Ω for A6 Versions.



## Outputs



### Analogue

Two freely selectable and scalable outputs	0 - 5 V / 0 - 10 V	-1 mA < $I_L$ < 1 mA	$I_L$ = load current $R_L$ = load resistance
	4 - 20 mA (2-wire)	$R_L \leq 500 \Omega$ $250 \leq R_L \leq 500 \Omega$ recommended for type T13	
	0 - 20 mA (3-wire)	$R_L \leq 500 \Omega$	

### Digital

Digital interface	RS485 (EE210 = 1 unit load)
Protocol Factory settings Supported Baud rates Data types for measured values	Modbus RTU Baud rate according to ordering guide, parity even, 1 stop bit, Modbus address 242 9 600, 19 200 and 38 400 FLOAT32 and INT16
Protocol Factory settings Supported Baud rates	BACnet MS/TP Baud rate according to ordering guide, parity none, 1 stop bit, BACnet address 1 9 600, 19 200, 38 400, 57 600, 76 800 and 115 200

## General

Power supply class III  USA & Canada: Class 2 supply necessary, max. voltage 30 V DC	4 - 20 mA (2-wire)	$(10 \text{ V} + R_L \cdot 20 \text{ mA}) < V_+ < 30 \text{ V DC}$ for type T13: 24 V DC $\pm 10\%$ recommended	
	0 - 5 V / 0 - 10 V 0 - 20 mA (3-wire) RS485	15 - 35 V DC or 24 V AC $\pm 20\%$	
Current consumption at 24 V	Voltage output	DC supply max. 12 mA AC supply max. 34 mA <sub>rms</sub>	with display max. 23 mA with display max. 49 mA <sub>rms</sub>
	Current output 2-wire	DC supply max. 40 mA	with display max. 40 mA
	Current output 3-wire	DC supply typ. 33 mA AC supply typ. 65 mA <sub>rms</sub>	with display max. 44 mA with display max. 84 mA <sub>rms</sub>
	Digital interface	DC supply typ. 5 mA AC supply typ. 15 mA <sub>rms</sub>	with display max. 20 mA with display max. 35 mA <sub>rms</sub>
Electrical connection	Screw terminals, max. 1.5 mm <sup>2</sup>		
Cable gland	M16x1.5		
Display <sup>1)</sup>	Available for type T1 / T2 / T3 1, 2 or 3 lines, user configurable Optional with backlight		
Temperature ranges		Without display	With display
	Operation	-40...+60 °C (-40...+140 °F)	-20...+50 °C (-4...+122 °F)
		-40...+80 °C (-40...+176 °F) for probe PE210	-40...+80 °C (-40...+176 °F) for probe PE210
Storage	-40...+60 °C (-40...+140 °F)	-20...+60 °C (-4...+140 °F)	
Enclosure	Material Protection rating	PC (Polycarbonate), UL94 V-0 (with display UL94 HB) approved IP65 / NEMA 4X	
Electromagnetic compatibility	EN 61326-1 FCC Part15 Class A	EN 61326-2-3 ICES-003 Class A	Industrial environment
Conformity	 		

1) For display operation with EE210-M1xA6 (4 - 20 mA, 2-wire) both outputs must be connected.

# 9 Conformity

## 9.1 Declarations of Conformity

E+E Elektronik Ges.m.b.H. hereby declares that the product complies with the respective regulations listed below:



European directives and standards.

and



UK statutory instruments and designated standards.

Please refer to the product page at [www.epluse.com/ee210](http://www.epluse.com/ee210) for the Declarations of Conformity.

## 9.2 Electromagnetic Compatibility

EMC for industrial environment.

Our sensors are group 1 devices and correspond to class A.

### WARNING

This device is not intended for use in residential areas and cannot ensure adequate protection of radio reception in such environments.

## 9.3 FCC Part 15 Compliance Statement

This equipment has been tested and found to comply with the limits for a Class A digital device, pursuant to part 15 of the FCC Rules. These limits are designed to provide reasonable protection against harmful interference when the equipment is operated in a commercial environment. This equipment generates, uses, and can radiate radio frequency energy and, if not installed and used in accordance with the instruction manual, may cause harmful interference to radio communications. Operation of this equipment in a residential area is likely to cause harmful interference in which case the user will be required to correct the interference at his own expense.

## 9.4 ICES-003 Compliance Statement

This Class A digital apparatus complies with Canadian ICES-003.

Cet appareil numérique de la classe A est conforme à la norme NMB-003 du Canada.

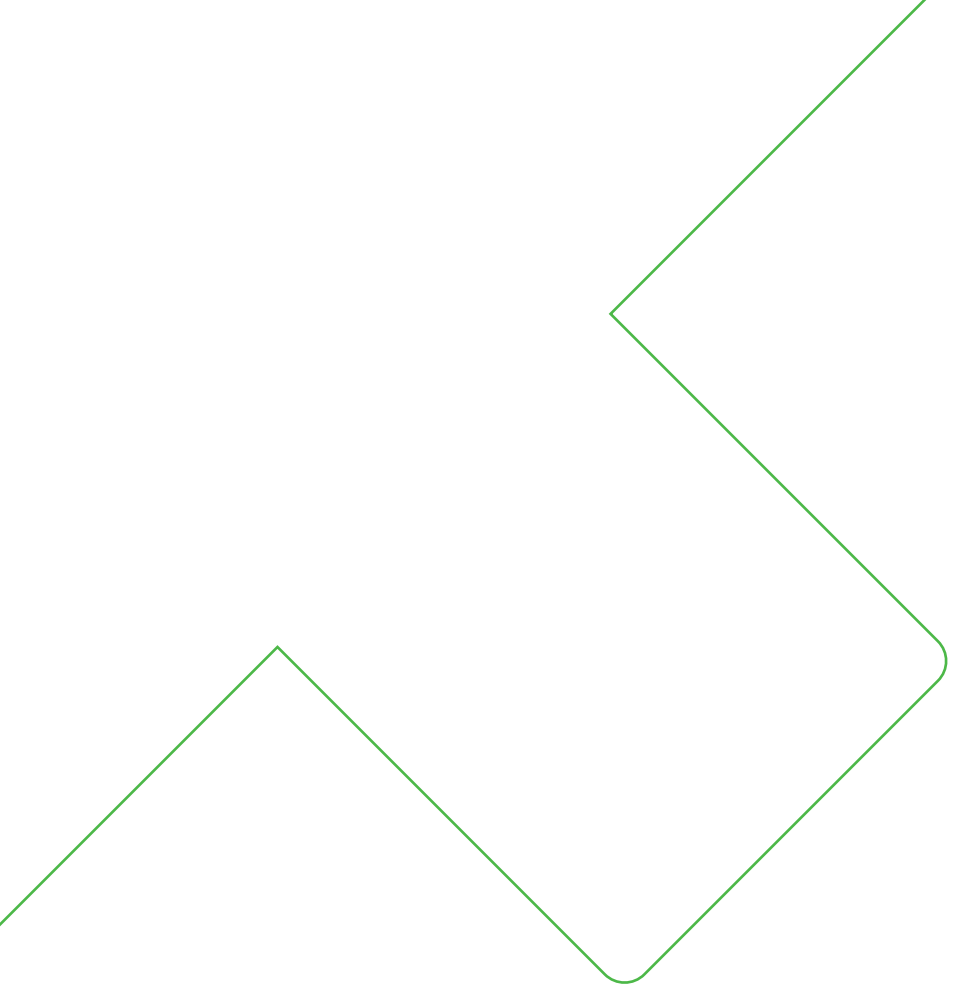

Company Headquarters &  
Production Site

**E+E Elektronik Ges.m.b.H.**  
Langwiesen 7  
4209 Engerwitzdorf | Austria  
T +43 7235 605-0  
F +43 7235 605-8  
info@epluse.com  
www.epluse.com

Subsidiaries

**E+E Sensor Technology (Shanghai) Co., Ltd.**  
T +86 21 6117 6129  
info@epluse.cn

**E+E Elektronik France SARL**  
T +33 4 74 72 35 82  
info.fr@epluse.com

**E+E Elektronik Deutschland GmbH**  
T +49 6171 69411-0  
info.de@epluse.com

**E+E Elektronik India Private Limited**  
T +91 990 440 5400  
info.in@epluse.com

**E+E Elektronik Italia S.r.l.**  
T +39 02 2707 86 36  
info.it@epluse.com

**E+E Elektronik Korea Ltd.**  
T +82 31 732 6050  
info.kr@epluse.com

**E+E Elektronik Corporation**  
T +1 847 490 0520  
info.us@epluse.com



—  
your partner  
in sensor  
technology.