

Kalyx-RG Rain Gauge User Manual



PUBLISHED BY

Environmental Measurements Limited (EML)

7 Jupiter Court

Orion Business Park

North Shields NE29 7SE

United Kingdom

Visit our internet pages at <http://www.emltd.net>



©EML 2017

No part of this manual may be reproduced without any form or by any means, electronic or mechanical (including photocopying), nor may its contents be communicated to a third party without prior written permission of the copyright holder.

The contents are subject to change without prior notice.

Please observe that this manual does not create any legally binding obligation for EML towards the customer or end user. All legally binding commitments and agreements are included exclusively in the applicable supply contract or Conditions of Sale.

Table of Contents

List of Figures	4
List of Tables	4
1. General Information	5
About this Manual	5
Version Information	5
2. Introduction	6
3. Site and Installation Requirements.....	6
Choosing a site	6
Levelling the rain gauge	7
Alternative mounting options.....	7
4. Wiring Guidelines.....	8
Wiring for internal loggers	9
5. Operation	9
Operation of the gauge	9
6. Maintenance and Calibration	10
Basic Maintenance	10
Calibration.....	11
7. Specifications	12
Gauge Specifications.....	12
Cable Specifications (if fitted)	12
Appendix A – Accessories	13

List of Figures

Figure 1 - Levelling the Gauge (gauge type for illustration purposes only)	7
Figure 2 - Kalyx-RG fitted to mast mounting arm	8
Figure 3 - Reed switch and resistor	8
Figure 4 - Filter in funnel.....	9
Figure 5 - Internal photograph highlighting water drains.....	10
Figure 6 - Pivot holding piece.....	11
Figure 7 - Removal of bucket	11
Figure 8 - Setting up the calibration	11
Figure 9 - Kalyx-RG calibration	11
Figure 10 - Aluminium Baseplate kit	13
Figure 11 - HDPE Baseplate kit.....	13
Figure 12 - Aluminium mast mounting arm.....	13
Figure 13 - Contents of spares kit	14
Figure 14 - Kalyx-RG spares kit.....	14

List of Tables

Table 1 - Document Revisions.....	5
Table 2 - Gauge Specifications	12
Table 3 - Cable Specifications (if fitted)	12

1. General Information

About this Manual

This manual is intended as a general guide for installing, wiring and using a Kalyx-RG rain gauge. The information contained in this manual may not cover all aspects of Kalyx-RG applications. Please refer to associated equipment manuals or consult papers and technical notes on the EML website (www.emltd.net).

Version Information

Table 1 - Document Revisions

EML Document Number:	Description:
UM-P-780-700	Version 1.0 - First Release, dated 19 th August 2015
UM-P-780-700	Version 2.0 - Second Release, dated 21 st September 2017

2. Introduction

The Kalyx-RG is EML's recommended solution for amateur meteorologists and hobbyists or for large project work on a budget, but still require scientific standard rain data. The gauge is based on the physical size of the traditional 5" Met Office rain gauge with EML's unique aerodynamic profile. The Kalyx-RG is a compact solution, an ideal rain measuring instrument for the garden, allotment, or cost-conscious professional.

The Kalyx-RG is available in White or Green - both complete with a standard low-density plastic tipping bucket calibrated to 0.2mm resolution. Both colour gauges are produced from UV stabilised external materials.

Traditional cylinder-shaped rain gauges are inaccurate due to the effect of wind blowing over the orifice. The physical presence of the gauge causes air to accelerate, carrying rainfall away from the collecting vessel. The effect of this can be up to a 20% reduction in rainfall catch. The unique aerodynamic shape of the EML range of scientific standard rain gauges reduces this effect, ensuring a high level of confidence in the accuracy of our measurements.

3. Site and Installation Requirements

Choosing a site

A rain gauge site is often a compromise between exposure requirements and operational constraints. The ideal site is level ground with a uniform scattering of objects in the surrounding area thus reducing overall wind speeds. However, these objects should not be too large to cause eddying or high gusts to occur near to the gauge, or so close to prevent rain from entering the gauge. The gauge should ideally be no closer than at least twice the height of the obstruction. Although the Kalyx-RG rain gauge is designed to operate in higher wind speeds, care must still be taken to avoid over-exposing the gauge where possible. Large expanses of open flat land should be avoided where possible. If the application is very specific, such as monitoring a building site, then the siting of the rain gauge is largely prescribed by use. Those users who wish to enquire more fully into rain gauge exposure are referred to the EML website for more technical information and papers (www.emltd.net).

WARNING! Remove packing piece! The tipping-bucket mechanism is immobilised before shipping to prevent damage in transit. To release the mechanism for use, remove the funnel assembly from its base by loosening the three screws and then lifting the funnel. Remove the piece of foam from under the bucket mechanism. This foam may be saved and used whenever the rain gauge is transported.

Levelling the rain gauge

The Kalyx-RG can be mounted directly or with one of our bespoke baseplates. The gauge must be levelled for correct operation, and it is important to ensure that the rim of the rain gauge is levelled precisely, using a spirit level; failure to do this will result in a systematic error. Levelling is one of the simplest means of improving accuracy of rainfall measurements. Although a small circular spirit level is provided in the base of the rain gauge, this is provided only as a quick check system, always level the rim of the funnel precisely and check regularly. The gauge is levelled by slackening the locking nuts on the adjustable feet, adjust feet for level and tighten locking nuts (Figure 1). Pegs can be fitted if necessary through the holes provided next to the adjusters.

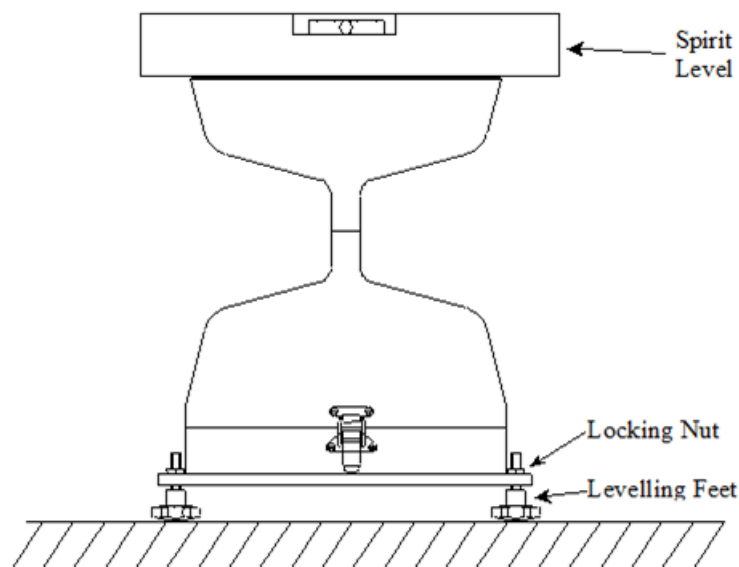

Figure 1 - Levelling the Gauge (gauge type for illustration purposes only)

Alternative mounting options

It is not always possible to mount a rain gauge on the ground surface. Examples of applications which make use of rain gauges mounted above the ground include; urban monitoring, areas prone to ground-flooding and areas prone to snowfall. It should be noted that regardless of which option is used to mount the gauge, it must be firmly fixed and not susceptible to vibration. Vibration may lead to 'false-tipping' of the bucket mechanism and thus contribute to erroneous or inaccurate measurements. There are options which can be used to mount the Kalyx-RG above the ground.

The Kalyx-RG can be purchased with one of two Baseplate options and Mast Mounting Arm option. This allows the user to connect the product to an existing pole or mast assembly (also available from EML). An example of this configuration is shown in Figure 2.



Figure 2 - Kalyx-RG fitted to mast mounting arm

Alternatively, the standard baseplate can be fixed to a standard wooden post (preferably concreted in the ground).

4. Wiring Guidelines

This section gives information on the wiring of Kalyx-RG rain gauge.

For most applications, the rain gauge may be connected directly to a pulse counting input (contact closure) on a data logger, but some care is needed if long cables are used. In a long cable, significant capacitance can exist between the conductors, which discharges across the reed switch as it closes. As well as shortening the life of the switch, a voltage transient may be induced in any other wires which run close to the rain gauge cable each time the rain gauges tips. To help this situation, 100Ω resistors are pre-fitted to the reed switch (Figure 3), this will help protect the switch from arcing and help prevent transients.

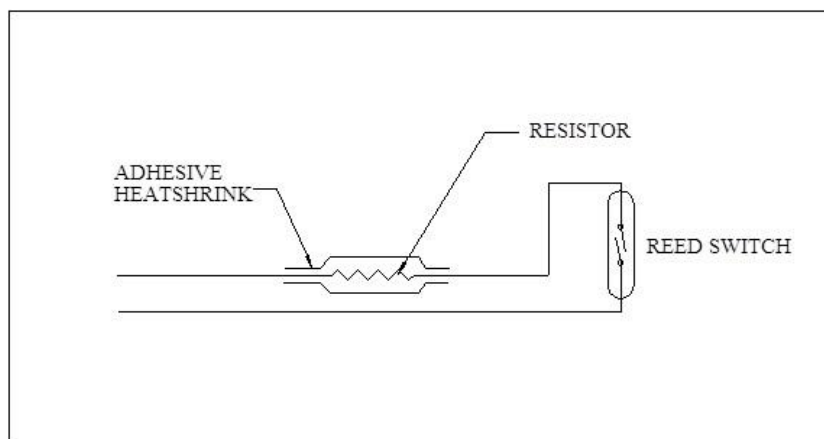

Figure 3 - Reed switch and resistor

Wiring for internal loggers

To connect an internal data logger or counter, two wires have to be connected to the green connector terminal block and taken to the contact closure input of your chosen logger.

The Kalyx-RG includes a 2-way terminal for connection (the green terminal). As this is a contact closure (switch) device it does not matter which way you connect this to your logger or counter.

5. Operation

Operation of the gauge

Rainfall is measured by the well-proven tipping bucket method. Precipitation is collected by the funnel and flows through a plastic filter, trapping and removing any leaves, dirt, etc. (Figure 4). Water then drips from the nozzle into one of the two halves of the tipping bucket.



Figure 4 - Filter in funnel

The internal tipping bucket assembly rotates around a rolling pivot. The balance arm tips when the first bucket is full, emptying this rain water and positioning the second bucket under the funnel. The tipping process repeats indefinitely as long as the rain continues to fall, with each tip corresponding to a calibrated fixed quantity of rainfall (normally 0.2mm for the Kalyx-RG). At each tip of the bucket the moving arm forces the magnet past the reed switch causing contact to be made for a few milliseconds. As each bucket side is used in turn, the outgoing water is drained away via outlets and discarded (Figure 5).

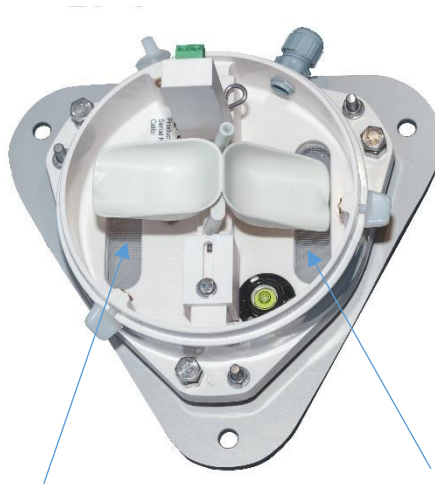

Figure 5 - Internal photograph highlighting water drains

The exact calibration of each tip is pre-set by adjustable stops. Do not alter these stops unless as part of a calibration exercise. A levelling bubble is provided as an aid to levelling of the rain gauge. Connections to the reed switch is made via the green connector terminals or with the cable provided.

6. Maintenance and Calibration

Basic Maintenance

To ensure reliable and accurate measurements it is recommended that the following checks are carried out at each visit to the rain gauge (if the gauge is still connected to a data logger and the logger is operating, care must be taken to avoid tipping the bucket when carrying out these checks). **Basic maintenance is especially important with the Kalyx-RG gauge as we are dealing with low quantities of rain water in the tipping bucket mechanism compared to other EML gauges – so any dirt build up will represent a significant change in weight. Please always keep your gauge clean to ensure accuracy! EML recommends a quick clean every one to two months.**

1. Inspect the funnel and filter for any damage or blockage. At certain times of the year, particularly autumn, leaves may accumulate in the funnel, dirt and dust can also block the filter preventing or reducing the flow rate to the buckets beneath. The leaves can easily be removed from the funnel and the filter cleaned by removing the end cap from the filter tube, remove the nylon filter gauze carefully, clean (or replace) and re-fit the filter and cap.
2. Check that the gauge is still level. Small movements may occur over time.
3. Remove and clean any dirt from the tipping bucket, being careful not to tip the bucket should the rain gauge still be logging.
4. During any occasion when the rain gauge is disconnected from the logger, it is good practice to check the balance arm of the tipping bucket for stiffness. The easiest way to do this in the field is to try and balance the bucket in its centre position, it should be very difficult if not impossible to achieve this, if the bucket balances easily then examine the bucket closely for any dirt or wear on the pivot pin and bucket tubes. If you need to remove the bucket, simply loosen the screw on the plastic pivot holding part (Figure 6) and carefully move away from the bucket. The bucket will then be easily removed (Figure 7). Please do not loosen or move the reed/green terminal holding part as this may affect operation.



Figure 6 - Pivot holding piece



Figure 7 - Removal of bucket

PLEASE NOTE: A spares kit is available with filter, cap, and screws. Contact EML sales (sales@emltd.net) for more information.

Calibration

The sensitivity of the rain gauge is accurately calibrated during the manufacturing stage (Figure 8 and Figure 9) to a nominal 0.2mm/tip using a purpose built calibration rig supplying an adjustable constant head of water allowing accurate calibration of the rain gauge. If requested at the ordering stage, each rain gauge is supplied with its own calibration figure otherwise the nominal 0.2mm should be used. All gauges are calibrated to a tolerance of 2% of the 0.2mm tip value.

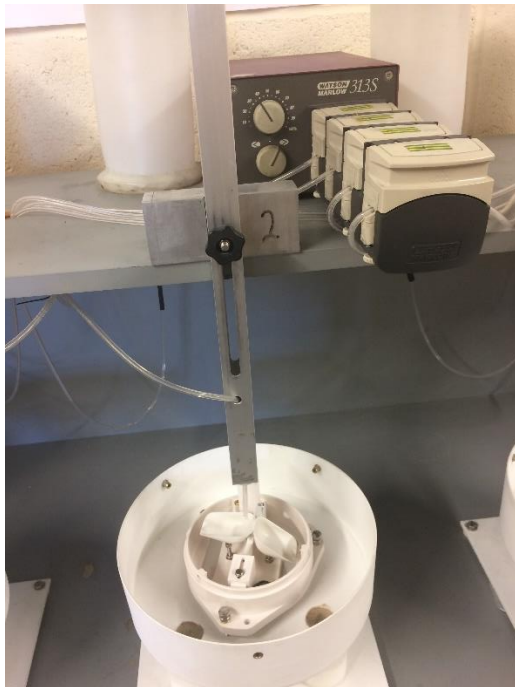

Figure 8 - Setting up the calibration



Figure 9 - Kalyx-RG calibration

A re-calibration and overhaul service is also offered to customers; EML recommends re-calibration every 12 to 24 months depending on applications.

7. Specifications

Gauge Specifications

Table 2 - Gauge Specifications

Technical Specifications	
Resolution	0.2mm / 0.01 inch
WMO Compliant	n/a
Output	Contact Closure (Reed Switch)
Typical Accuracy	99% up to 120mm/hr
Rainfall Intensity	0-2000 mm/hr (with mathematical correction - contact EML)
Operating Temperature	1°C - 70°C
Funnel Diameter	12.7cm / 5 Inch
Funnel Area	127cm ² / 19.64 sq.Inch
Height	225mm or 245mm max with baseplate
Weight	700g or 1Kg (with baseplate)
Colour	White or Green

Cable Specifications (if fitted)

The standard cable used in all extended versions (on request) of the rain gauge is a single twisted pair of 7/0.25mm (22awg) tinned copper conductors, insulated with polyethylene, wrapped in an aluminised tape with a 7/0.25mm tinned drain wire and a PVC outer sheath.

Table 3 - Cable Specifications (if fitted)

Technical Specifications	
Temperature Range	-30°C to +70°C
Overall diameter	4.6 mm
Char. impedance	85 Ω
Capacitance/metre	154 pF
Equivalents	Alpha 2401 Belden 8761 UL style 2092

Appendix A – Accessories

Optional bespoke anodised aluminium baseplate kit:

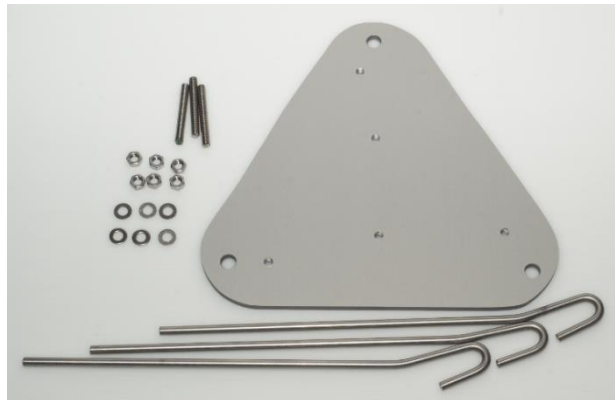

Figure 10 - Aluminium Baseplate kit

Optional bespoke HDPE baseplate kit:

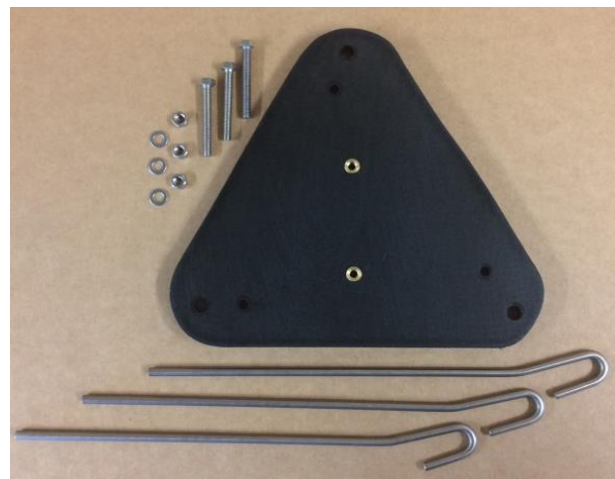

Figure 11 - HDPE Baseplate kit

Optional bespoke Anodised aluminium mast mounting arm:



Figure 12 - Aluminium mast mounting arm

Kalyx-RG Spares Kit:

The Kalyx-RG spares kit comprises of three new funnel screws, two filter caps and two piece of filter material.

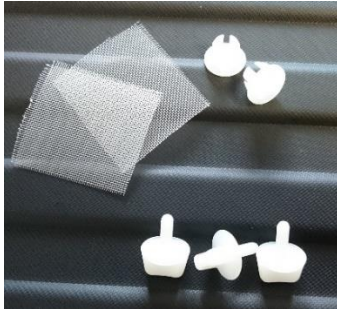

Figure 13 - Contents of spares kit



Figure 14 - Kalyx-RG spares kit