

USH-9

Ultrasonic level sensor

Manual

Setup version 2.45 (Firmware 1.83)

10 March, 2020



Sommer Messtechnik

All rights reserved.

The Copyrights for this manual are exclusively owned by

Sommer Messtechnik
6842 Koblach
Austria

This manual or parts of it may only be copied or passed on to third parties with written permission of Sommer Messtechnik. This applies to printed as well as digital issues of this manual.



Sommer Messtechnik
Strassenhäuser 27
6842 Koblach
Austria
www.sommer.at
E office@sommer.at
T +43 5523 55989
F +43 5523 55989-19

Validity

This manual applies to the Ultrasonic level sensor with the setup version 2.45, including all its sub-versions.

Created: 19 Sept, 2018

Last update: 10 March, 2020



EU conformity



This product is in conformity with the following standards:

EMC	2014/30/EU	EN 301 489-1 V1.9.2
RoHS II	2011/65/EU	
RoHS III	2015/863/EU	

FCC compliance



This device complies with Part 15 of the FCC Rules. Operation is subject to the following two conditions: (1) This device may not cause harmful interference, and (2) This device must accept any interference received, including interference that may cause undesired operation.

FCC ID: UXSIMS944

Feedback

Should you come across any error in this manual, or if you miss information to handle and operate the USH-9 we are very grateful for your feedback to office@sommer.at.

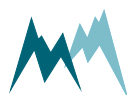

Safety information

Please read this manual carefully before installing or operating this equipment. Non-compliance with the instructions given in this manual can result in failure or damage of the equipment or may put people at risk by injuries through electrical or mechanic impact.

- Installation and electrical connections must be carried out by qualified personnel familiar with the applicable regulations and standards.
- Installation of equipment on towers, bridges and in discharge channels poses the risk of falling, slipping or dropping of objects. Contact your safety officer or consult applicable safety regulations for precautions and proper personal safety equipment.
- Do not perform any installations in bad weather conditions, e.g. thunderstorms.
- Prior to installation of equipment inform the owner of the measurement site or the authority responsible for it. Upon completion, secure the installation from trespassers.
- Maintenance and repair must be performed by trained personnel or an engineer of Sommer Messtechnik. Only replacement parts supplied by Sommer Messtechnik should be used for repairs.
- Make sure that NO power is connected to the equipment during installation and wiring.
- Only use a power supply that complies with the power rating specified for this equipment.
- Keep equipment dry during wiring and maintenance.
- If applicable, it is recommended to use accessories of Sommer Messtechnik with this equipment.

Disposal



After this device has reached the end of its lifetime, it must not be disposed of with household waste! Instead, dispose of the device by returning it to a designated collection point for the recycling of waste electrical and electronic equipment.

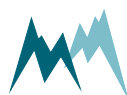

Content

1	What is the USH-9?	10
2	Unpacking	11
3	How do I start?	12
3.1	Connect the USH-9 to a PC	12
3.2	Configure the sensor	13
3.3	Acquire measurements	13
4	Specifications	14
5	Connectors	16
5.1	Main	16
6	How does the USH-9 work?	17
7	Installation	18
7.1	Where should I install the USH-9?	18
7.2	What do I need?	18
7.3	How do I install the USH-9?	18
7.3.1	Mounting	18
7.3.2	Power supply	20
7.3.3	Signal cables	20
7.3.4	Lightning protection	21
8	Maintenance	22
8.1	How do I test the USH-9 indoors?	22
9	Support software Commander	23
9.1	What can I do with it?	23
9.2	How do I install it?	23
9.2.1	System requirements	23
9.2.2	Installation procedure	23
10	Configuration	29
10.1	Configuration with Commander support software	29
10.2	Configuration with a terminal program	31
10.3	Configuration errors	33
10.3.1	Conflict messages	33
10.4	What do I need to configure?	35
10.4.1	General settings	35
10.4.2	Level/Distance measurement	37

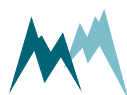

10.5	How do I configure the USH-9 for snow measurements?	39
10.6	How do I configure the USH-9 for water level measurements?	39
11	Serial communication	41
11.1	What are the options?	41
11.2	Which data do I get?	41
11.2.1	Main values	41
11.2.2	Special values	42
11.2.3	Analysis values	42
11.2.4	Exception values	43
11.3	RS-485	44
11.3.1	What is it?	44
11.3.2	What can I do with it?	44
11.3.3	How do I wire it?	44
11.3.4	How do I configure it?	44
11.3.5	How is the output structured?	47
11.3.6	Sommer protocol	47
11.3.7	Standard protocol	51
11.3.8	Which commands are available?	54
11.3.9	Sommer CRC-16	56
11.4	SDI-12	56
11.4.1	What is it?	56
11.4.2	What can I do with it?	56
11.4.3	How do I wire it?	56
11.4.4	How do I configure it?	57
11.4.5	How are commands structured?	57
11.4.6	Which commands are available?	57
11.5	Modbus	61
11.5.1	What is it?	61
11.5.2	What can I do with it?	61
11.5.3	How do I wire it?	61
11.5.4	How do I configure it?	62
11.5.5	How do I switch back to Sommer protocol?	66
11.5.6	Which commands are available?	71
11.5.7	PLC integration	76
12	Analog output	77
12.1	What can I do with it?	77
12.2	How do I wire it?	77
12.3	How do I configure it?	77
12.3.1	Output status	78

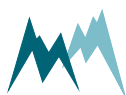

12.3.2	IOUT 1	78
12.3.3	IOUT 2	79
12.3.4	Simulate current output	80
13	Parameter definitions	81
A	Measurement trigger	81
B	Measurement Interval	81
C	Level and distance	82
C-A	Measurement duration	82
C-B	Level/distance test	82
C-C	Adjust level	82
C-D	Distance to zero level	82
C-E	Application	83
C-F	Moving filter, duration	83
C-G	Moving filter, type	84
D	Technics	84
D-A	Language/Sprache	84
D-B	Decimal character	85
D-C	SDI-12 address	85
D-D	Units and decimals	85
D-D-A	Level, unit	85
D-D-B	Level, decimals	86
D-D-C	Temperature, unit	86
D-D-D	Temperature, decimals	86
D-E	Temperature	86
D-E-A	Offset	87
D-E-B	Adjustment	87
D-E-C	Test	87
D-F	IOUT settings	87
D-F-A	Output status	87
D-F-B	IOUT1, function	88
D-F-C	IOUT1, 4-20 mA span	88
D-F-D	IOUT1, 4 mA value	88
D-F-E	IOUT2, function	89
D-F-F	IOUT2, temperature 4-20 mA span	89
D-F-G	IOUT2, temperature 4 mA value	89
D-F-H	IOUT2, status hold time	90
D-F-I	Simulate current output	90
D-G	Status limits	90
D-G-A	Level limit	90

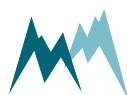

	D-G-B	Snow settling, strength drop	91
	D-G-C	Snow settling, maximum level	91
	D-G-D	Snowfall, precipitation limit	91
	D-G-E	Snowfall, max. temperature	92
D-H		Advanced settings	92
	D-H-A	Optimisation	92
	D-H-B	Max. measurement distance	92
	D-H-C	View spectral distribution	93
	D-H-D	Maximum standard deviation	93
	D-H-E	Rate of change, maximum (./h)	93
	D-H-F	RoC, max. without precip. (./h)	93
	D-H-G	RoC, max. at precip. (./h)	94
	D-H-H	Precipitation, filter duration	94
	D-H-I	Reset behavior	94
	D-H-J	Sleep mode	95
	D-H-K	Sommer ID	95
D-I		RS-485 Protocol	95
	D-I-A	Device number	95
	D-I-B	System key	96
	D-I-C	Output protocol (OP)	96
	D-I-D	OP, measurement output	96
	D-I-E	OP, information	97
	D-I-F	OP, wake-up sequence	97
	D-I-G	OP, prefix holdback	97
	D-I-H	MODBUS, set default	98
	D-I-I	MODBUS, device address	98
D-J		RS-485 Port	98
	D-J-A	Baud rate	98
	D-J-B	Parity, stop bits	98
	D-J-C	Minimum response time	99
	D-J-D	Transmitter warm-up time	99
	D-J-E	Flow control	99
	D-J-F	Sending window	100
	D-J-G	Receiving window	100
E		Special functions	100
	E-A	Device status	100
	E-B	View setup	100
	E-C	Continuous meas. mode (temp).	100
	E-D	Set factory default	101
	E-E	Temp. load factory default	101

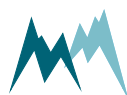

E-F	Relaunch program	101
F	Measurement table	101
Appendix A	Device Errors	102

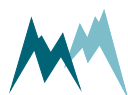

1 What is the USH-9?

Continuous snow depth and water-level measurements are very important in avalanche risk forecast and water resource management .

The USH-9 is a continuous measurement device for the contact-free determination of snow depth and water level. It measures the transit time of an ultrasonic signal between a variable surface and the USH-9 sensor, and translates it to a snow or water level. An integrated processor compensates the detected signal for temperature and filters interfering reflections of precipitation within the measurement path.

The USH-9 sensor contains an additional feature to sense precipitation and to discriminate snow from rain. This offers the option to detect the settling of snow, used for example in road weather monitoring systems.

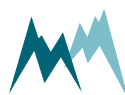

2 Unpacking

When unpacking your USH-9 sensor box please make sure that the following items are present:

Item
USH-9 sensor including sensor mount, sensor cable 10 m and RS-485 to USB converter
Manual and Commander Software on USB stick
Commander software

In case of missing or damaged items please contact your Sommer sales partner.

Available accessories

Art	Accessory
20789	MAIN sensor cable SQ/USH-9, 10 m
20791	MAIN sensor cable SQ/USH-9, 20 m
21150	USB to RS485 isolated converter cable

Modbus converters (PROFIBUS, CANOpen, PROFINET, EtherCat) are available on request.

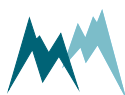

3 How do I start?

Follow the steps described below to set the basic configurations and to acquire the first measurement results.



NOTE Perform the first start-up in your lab or office before installing the equipment in the field!

3.1 Connect the USH-9 to a PC

1. Install the Commander support software (see [How do I install it?](#))
2. Connect the yellow and gray wire of the sensor cable to the USB to RS485 isolated converter cable and plug it into your PC as illustrated in the figure below.
3. Connect a 9...28 VDC power supply to the USH-9
4. Start the Commander software.
5. Click on **Communication assistant** on the right-hand side of the Commander window and follow the instructions. During this procedure the communication assistant will search for connected devices. Upon successful completion, the new connection is added to the connections list (tab **Connections (F8)**).
6. In the **Communication** Section at the right-hand side of the Commander window select Mode **Connection** and the previously created connection from the drop-down list.
7. Click **Connect** to establish a connection with the USH-9. If the connection was successful a green icon is displayed at the top-right corner of the Commander window.
8. Select the tab **Parameters (F2)** and click **Download parameters from device** on the left side of the Commander-window. The complete parameter list is transferred from the sensor to your PC and displayed in the **Parameter** window.

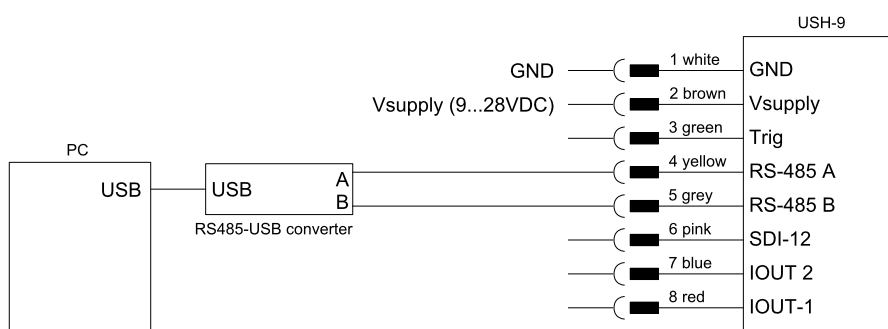
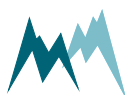

Figure 1 Wiring of the USH-9 to a PC



3.2 Configure the sensor

1. Select language, decimal character, units and decimal places (see [What do I need to configure?](#))
2. Select the measurement trigger (see [What do I need to configure?](#))
3. Configure the USH-9 for the required application (see [How do I configure the USH-9 for snow measurements?](#), [How do I configure the USH-9 for water level measurements?](#) and [Level/Distance measurement](#))
4. Define scope and structure of the data output (see [General settings](#))
5. Optional: Configure analog outputs (see [How do I configure it?](#))
6. Send any modifications to the USH-9 by clicking [Upload modified parameters to device](#).

3.3 Acquire measurements

Select the tab [Measurement \(F3\)](#) and click Start polling measurements. Select [Polling with measurements](#) and confirm the Warning. Now, the device performs consecutive measurements at the fastest possible rate. Click [Stop polling](#) to cancel data acquisition.

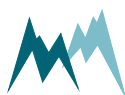

4 Specifications

Physical and environmental	
Power supply	9...28 VDC; Reverse voltage protection, overvoltage protection
Power consumption at 12 VDC	Sleep mode: <0.4 mA Active measurement: typically 40 mA (max. 300 mA for 0.05 s)
Outputs	RS-485 ASCII / Modbus RTU SDI-12 2 Analog outputs 4...20 mA (14 bit, max. load 250 Ω)
Operating temperature	-40...60 °C (-40...140 °F)
Storage temperature	-40...60 °C (-40...140 °F)
Environmental humidity	0...100 %rH
Protection rating	IP 64
Lightning protection	Integrated protection against indirect lightning with a discharge capacity of 0.6 kV peak
Housing material	Anodized aluminium
Mounting bracket	Ø32...60 mm
Size Ø x H	Ø180 x 320 mm
Weight	1.2 kg

Snow depth measurement	
Measurement range	0.7...10 m
Near blanking distance	0.7 m
Accuracy	max. ± 1cm; typically 0.1% FS
Resolution	1 mm
Non-linearity	≤0.15%



Measurement duration	2...20 s
Measurement interval	20 s...3 h
Measurement principle	Ultrasonic (frequency 50 kHz)
Beam aperture	12°

Temperature measurement

Temperature sensor	Pt1000 with radiation shield
Measurement range	-40...60 °C (-40...140 °F)
Accuracy	0.3 °C
Resolution	0.01 °C

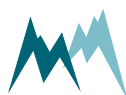

5 Connectors

5.1 Main

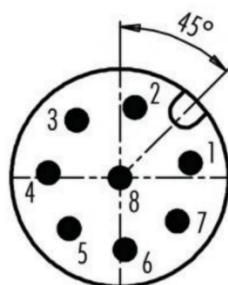

Figure 2 MAIN connector

	Pin	Colour ¹	Function	Description
Power supply	1	white	GND	Ground
	2	brown	Vsupply	9...28 VDC
Trigger input	3	green	Trig	low: 0...0.6 V, high: 2...27 V
RS-485 interface	4	yellow	RS485 A ²	1 x RS-485 (1200...115200 Baud)
	5	grey	RS485 B ²	
SDI-12 interface	6	pink	SDI-12	1 x SDI-12 (1200 Baud)
Analog outputs	7	blue	IOUT2	Temperature (4...20 mA)
	8	red	IOUT1	Snow depth (4...20 mA)

Table 1: Configuration of connector MAIN



NOTE The analog outputs and the trigger input are referenced to GND on pin 1.

¹Wire colour of the provided "Sommer" cable

²According to TI notation which differs from the standard EIA notation

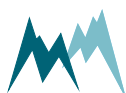

6 How does the USH-9 work?

The USH-9 is a sensor to measure distance contact-free. Ultrasonic pulses with a frequency of 50 kHz are emitted from the sensor-head and are reflected at any surface. The reflected signal is then detected by the sensor and from the travelling-time of the pulses the distance to the surface is calculated. Figure 3 illustrates the path of the ultrasonic signal.

The ultrasonic pulses received by the sensor head are filtered for interferences and disturbing reflections, e.g. from precipitation. This permits reliable and accurate level measurements even during rain or snowfall, or when the snow is of very low density.

As the speed of sound depends on temperature, the USH-9 is equipped with an integrated Pt1000 air temperature sensor to automatically correct the measured distance and snow depth.

With the integrated, intelligent signal processing and the automatic switching between standby- and measurement-mode the power consumption can be minimized. With a 12-Ah battery the USH-9 can be operated for approx. 24 days with one measurement per minute.

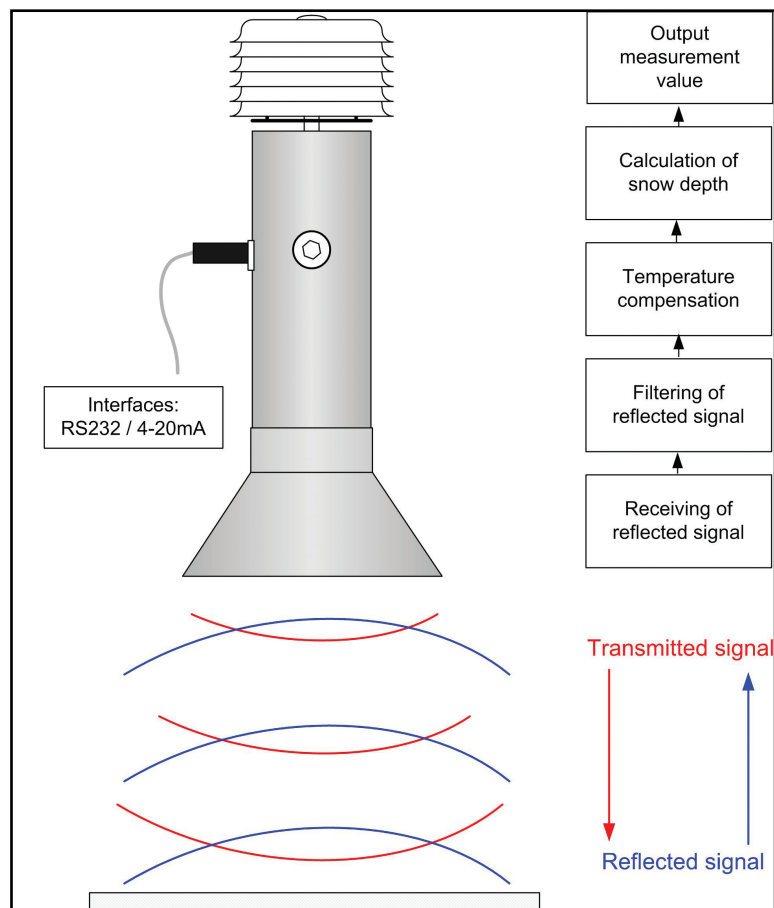

Figure 3 Ultrasonic signal of the USH-9 sensor

7 Installation

7.1 Where should I install the USH-9?

The selection of a suitable site is crucial to gain accurate water levels and snow depth data that are representative of the monitored area. Several aspects have to be considered when choosing a site, especially for snow depth measurements:

1. The measurement spot should be representative of the monitored area. This applies to the weather conditions as well as to the ground surface. Different surfaces, e.g. grass and gravel, have different thermal properties and consequently influence snow accumulation and snow melt.
2. The terrain should be flat or only be slightly sloping. There should be no troughs or hills.
3. There should be no boulders, trees, fences or other objects on and around the measurement spot. Any obstacle can cause snow drift and thus affect the snow depth measurement.
4. The site should be exposed to wind as little as possible.
5. The site must be safe from avalanches.
6. If the measurement spot is on or near a slope any snow gliding has to be ruled out.

7.2 What do I need?

Prepare the following equipment and tools to install the USH-9:

- mounting tube $\varnothing 32 \dots 60$ mm
- 13 mm open end wrench
- cable ties
- wire cutter

7.3 How do I install the USH-9?

7.3.1 Mounting

The USH-9 can be mounted to a horizontal tube with the included bracket (max. tube diameter 60 mm) as shown in [Figure 4](#).



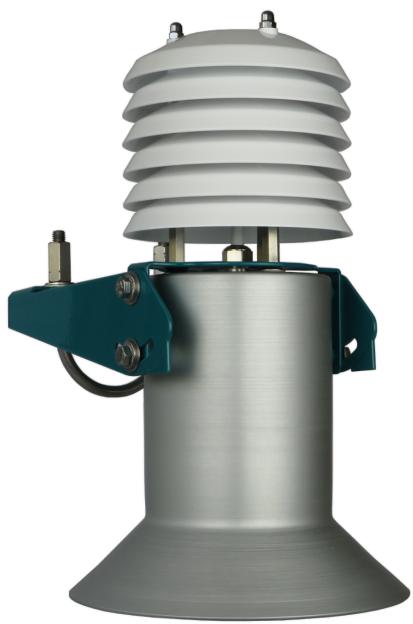
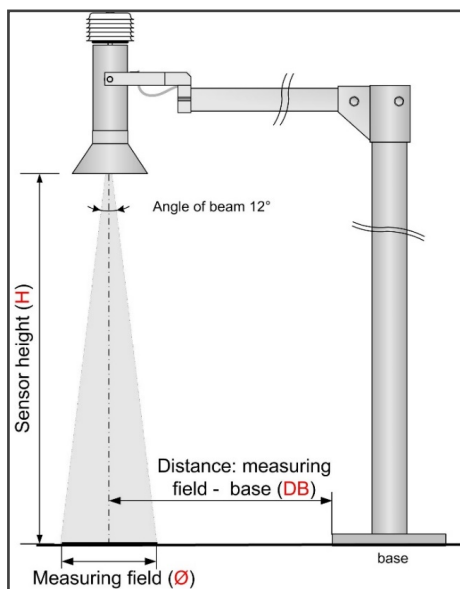

Figure 4 USH-9 with mounting bracket

When planning the installation of a USH-9 the extension of the cone-shaped measurement beam has to be taken into account. The higher the sensor is mounted the bigger the diameter of the measurement spot. Consequently, the mast and cross-beam must be designed in such a way that they do not interfere with the ultrasonic beam and thus create unwanted reflections. The same applies to river banks and channel walls in water level applications. Consult the table in Figure 5 for recommended distances between mast and measurement spot.



H [m]	Ø [m]	DB [m]
2	0.6	1.0
3	1.0	1.2
4	1.3	1.4
5	1.6	1.6
6	1.9	1.8
7	2.2	2.0
8	2.5	2.2

Figure 5 Measurement spot and USH-9 position

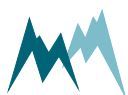

It is recommended to mount the USH-9 one meter above the maximum expected level and minimum 3 m above ground. The maximum mounting height is 10.5 m above ground. As an accessory, Sommer provides a 1.6 m long, rotatable cross-arm for easy sensor mounting.

For accurate measurements the USH-9 should be mounted within $\pm 6^\circ$ perpendicular to the snow/ground surface.



ATTENTION

If the measurement spot is sloping, make sure the USH-9 is mounted perpendicular to the snow/ground surface! Also, do not install the USH-9 on a horizontal podium in the slope!

Never tilt the USH-9 towards the base of the mast as this can cause unwanted reflections. To avoid such a situation, consider rotating the mast or selecting another measurement spot.

If a snow-depth monitoring site needs to be secured by a fence, the distance between the fence and the USH-9 should be large enough to avoid snow build-up or snow drift.

7.3.2 Power supply

The USH-9 is designed for extreme environmental conditions at remote sites and with no grid connection. The sensor switches automatically into standby-mode between measurements and thus consumes only approx. 0.2 Ah per day (measurement duration 6 sec and measurement interval 60 sec) which can be supplied by a 12V-solar-generator mounted to the mast.

7.3.3 Signal cables

Please consider the maximum cable lengths for the applied transmission protocol:

Protocol	Max. cable length [m]
SDI-12	60
RS-485	300

Table 2: Maximum cable lengths



NOTE Cable lengths longer than 60 m require a heavier gauge wire if the power supply drops below 11 V.

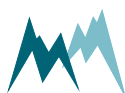

7.3.4 Lightning protection

If the underground at the measurement site permits sufficient current dissipation it is strongly recommended to equip the sensor support or mast with properly dimensioned lightning protection. Consult an expert for advice.

The USH-9 is protected against overvoltage. If a data logger is mounted to the mast, its ground lug must be properly connected to earth ground.

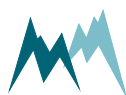

8 Maintenance

The USH-9 generally does not require any special maintenance. However, the device should be inspected occasionally for damage and a dirty sensor surface. To remove dirt use a wet cloth with little force. Do not use any abrasive detergent or scraping tool!

8.1 How do I test the USH-9 indoors?

To test the USH-9 and to verify its distance/level measurements turn the device upside down so that it is facing the ceiling of a room. Now, click the button [Level/distance test](#) in the [Level and distance](#) menu. The USH-9 then triggers a measurement and returns the current distance and level.

Place a sturdy, flat object (e.g. book) underneath the USH-9 and perform additional measurements to check a second distance/level.



ATTENTION If the USH-9 is configured for snow applications do not use the general measurement function ([Measurement \(F3\)](#)-tab) of the Commander! The snow application mode has a measurement filter (Rate of change filter, RoC) that suppresses abrupt level changes. Thus, it may take some time for the USH-9 to read the actual distance.

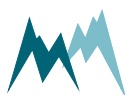

9 Support software Commander

9.1 What can I do with it?

The Commander is a multipurpose software tool to configure and operate any Sommer Messtechnik device. It offers the following functions:

- Communication with Sommer Messtechnik sensors and data loggers via serial connection, modem, socket, IP-call and Bluetooth®
- Management of connections and stations
- Configurations of sensors and data loggers
- Live data monitoring and storage
- Data management including download from data loggers and transmission to MDS (Measurement Data server)
- Terminal window to check data transfer and to access device settings directly
- Spectrum-Mode to visualize radar and ultrasonic spectra (used for diagnostic purposes, e.g., multiple reflections)

9.2 How do I install it?

9.2.1 System requirements

The Commander software supports 32- and 64-bit versions of Windows 7 SP1, Windows 8, Windows 8.1 and Windows 10.

For correct operation Microsoft® .NET Framework 4.5 or later must be installed.

9.2.2 Installation procedure

Follow the steps below to install the Commander software:

1. Double-click the [commander.msi](#) installer file
2. Click [Next](#) on the pop-up window

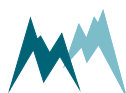



3. Read the instructions and click [Next](#)

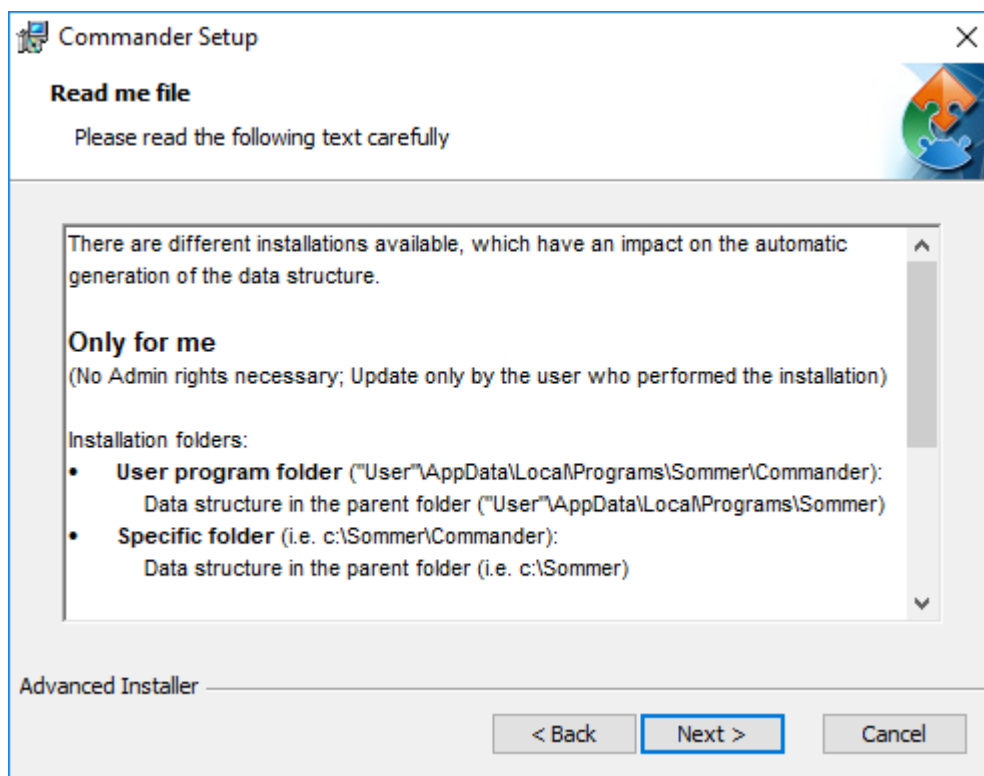

4. Select the installation type and click [Next](#)



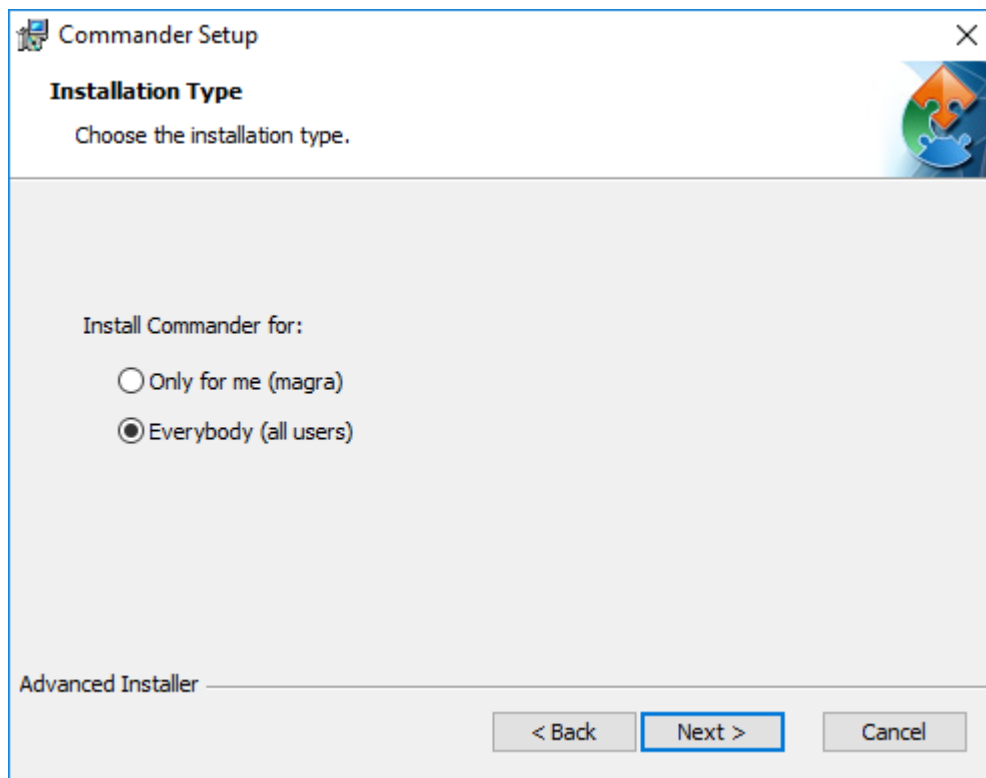

NOTE

Two installation types are available. Depending on the selection, the access rights and the folder structure differ:

Only for me

No admin rights are required. Updates are only available to the user who installed the software.

Installation folders:

- User program folder:
Users\User\AppData\Local\Programs\Sommer\Commander
Data structure:
Users\User\AppData\Local\Programs\Sommer
- Specific folder (default):
C:\Sommer\Commander
Data structure (default):
C:\Sommer

Everybody

Admin rights are required. Updates may only be performed by system administrators.

Installation folders:





- Standard program folder:
Program Files (x86)\Sommer\Commander
Data structure:
Users\Public\Public documents\Sommer
- Specific folder (default):
C:\Sommer\Commander
Data structure (default):
C:\Sommer

5. Select the installation directory and click **Next**.

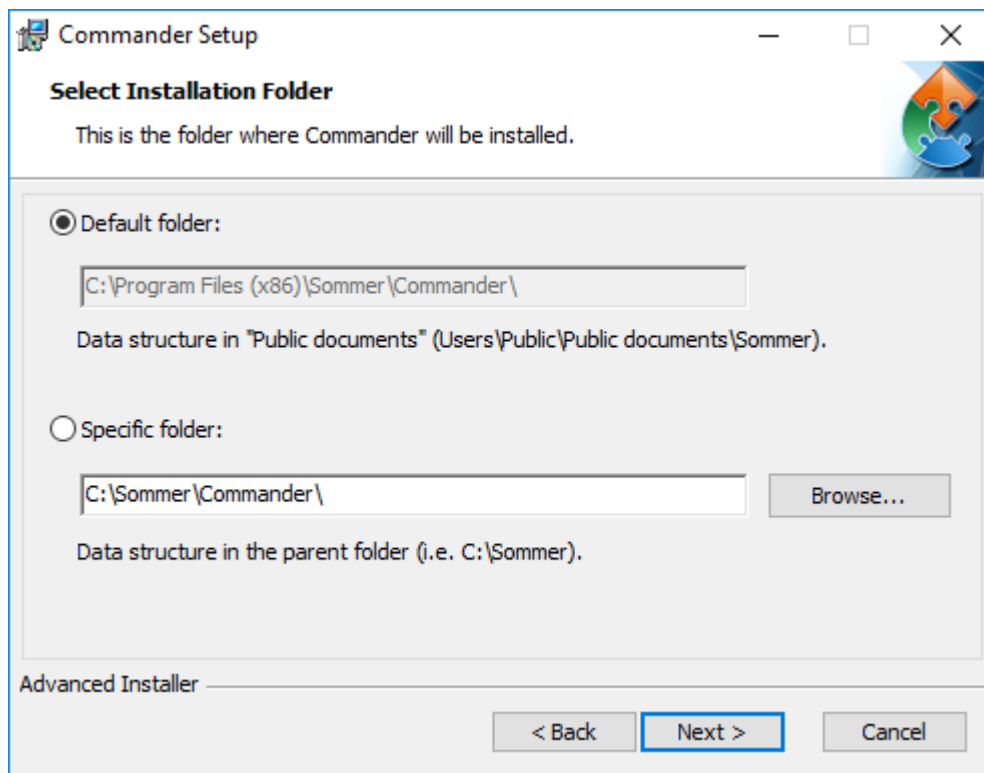

6. Select the features to be installed and click **Next**.



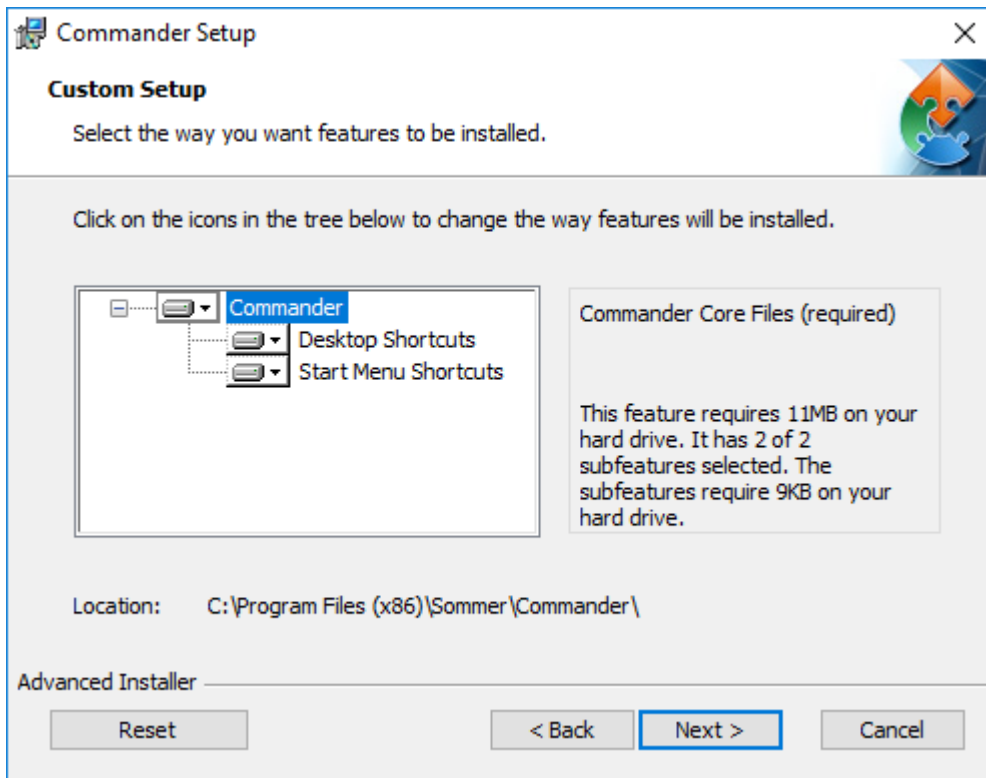

7. Click **Install** to start the installation.

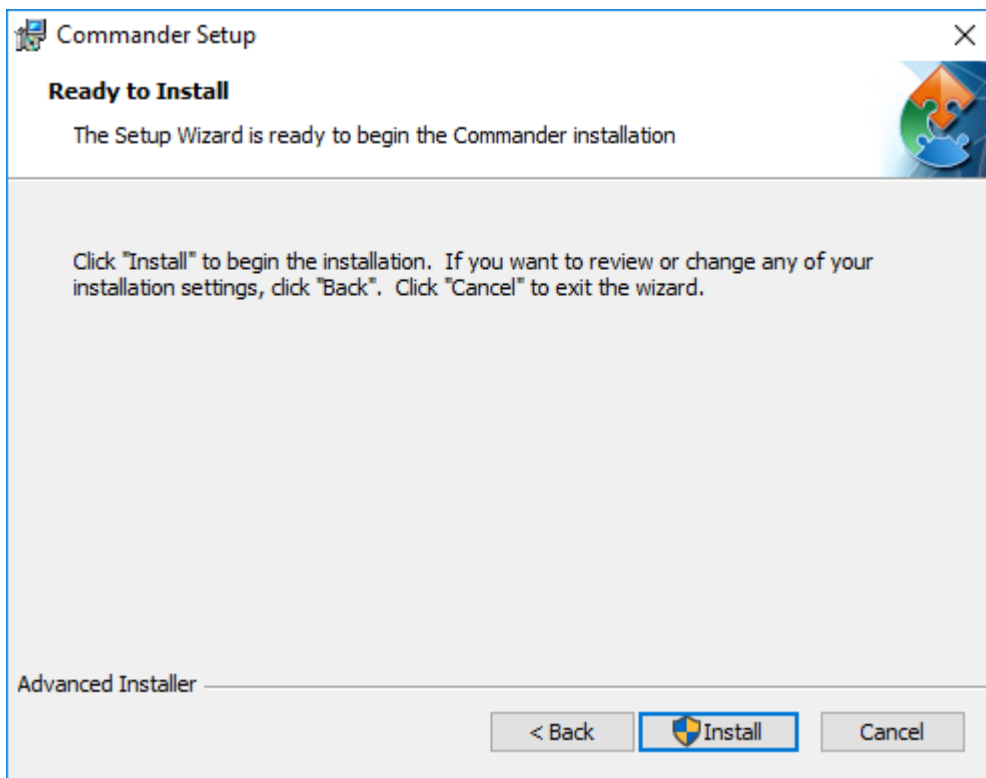

8. Click **Finish** to complete the installation.

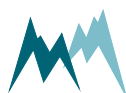

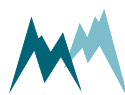
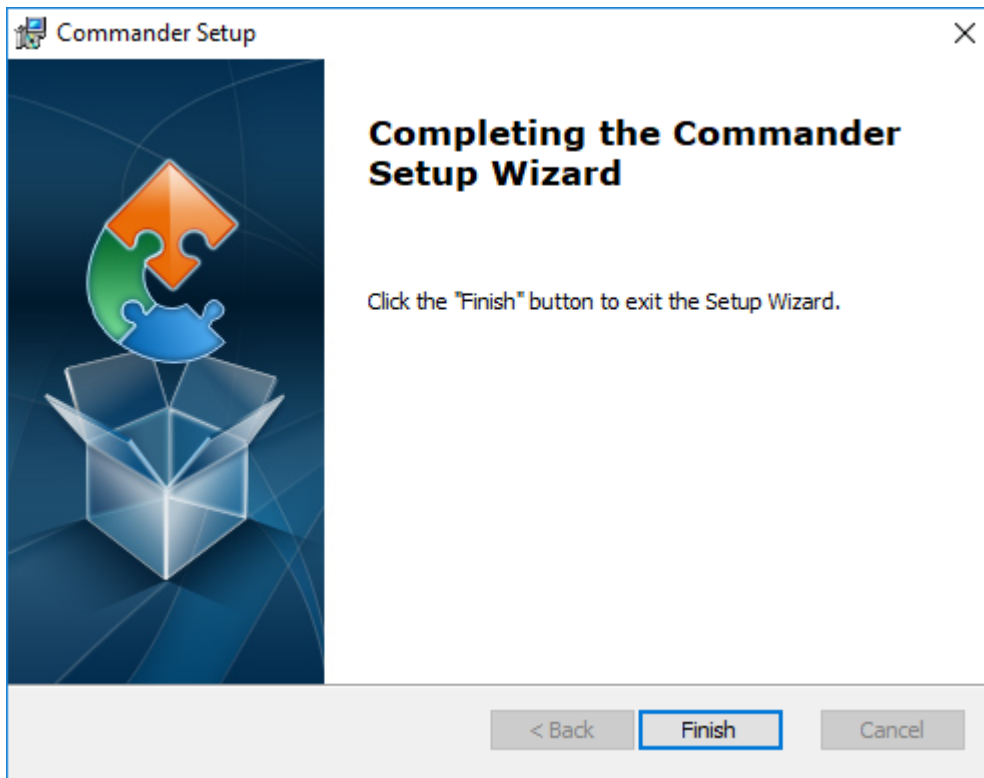

10 Configuration

The USH-9 can be configured with one of the following tools:

- Configuration with Commander support software
- Configuration with a terminal program

10.1 Configuration with Commander support software

Follow the steps below to modify the configuration parameters of the USH-9:

1. Establish a connection between your PC and the USH-9 as described in [Connect the USH-9 to a PC](#).
2. Select the tab **Parameters (F2)** and click **Download parameters from device**. The complete parameter list is transferred from the sensor to your PC and displayed in the Parameter window.

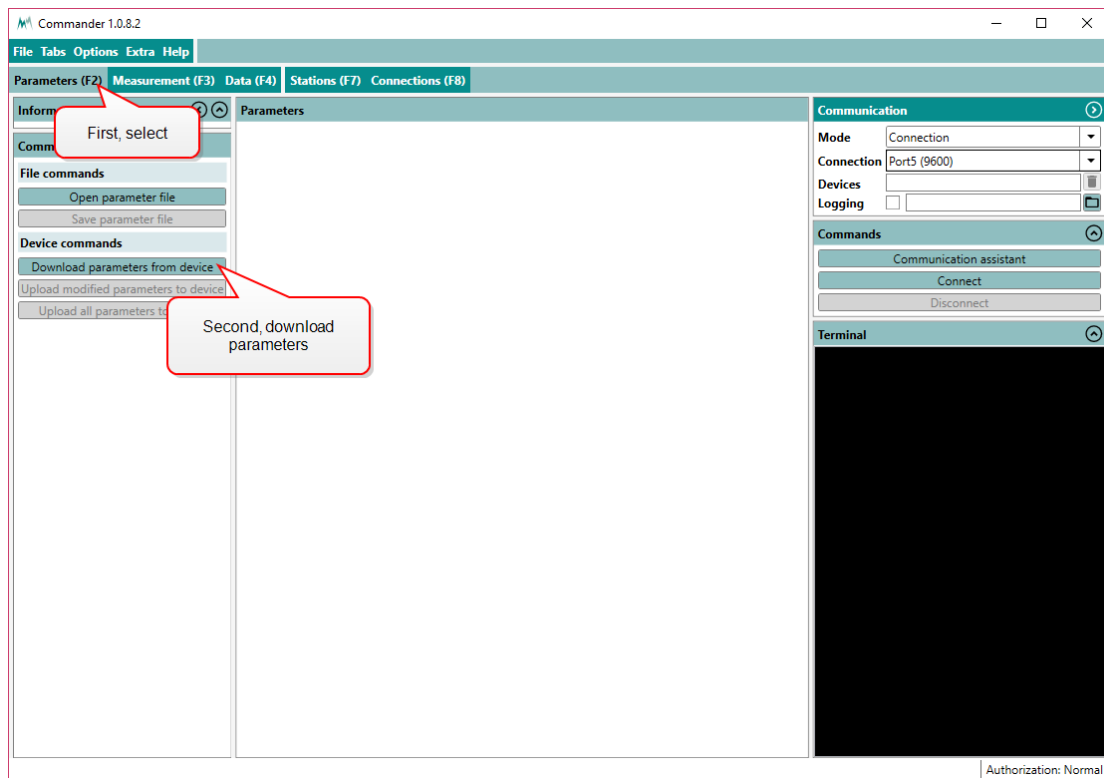

NOTE The first download of the parameter list may take a few minutes. After that the device is known to the PC and consecutive downloads are much faster.

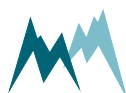

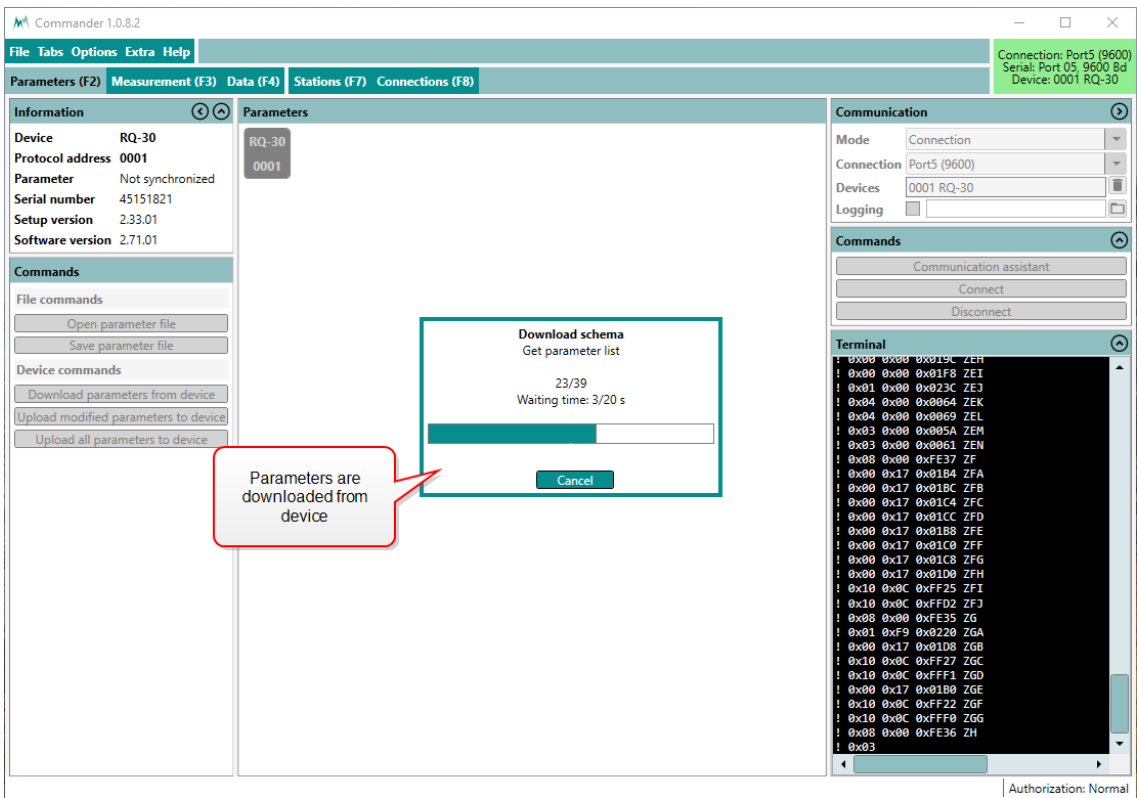

3. Save the parameter file to your PC by clicking **Save parameter file**. This step is recommended to track any configuration changes.

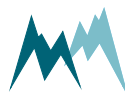
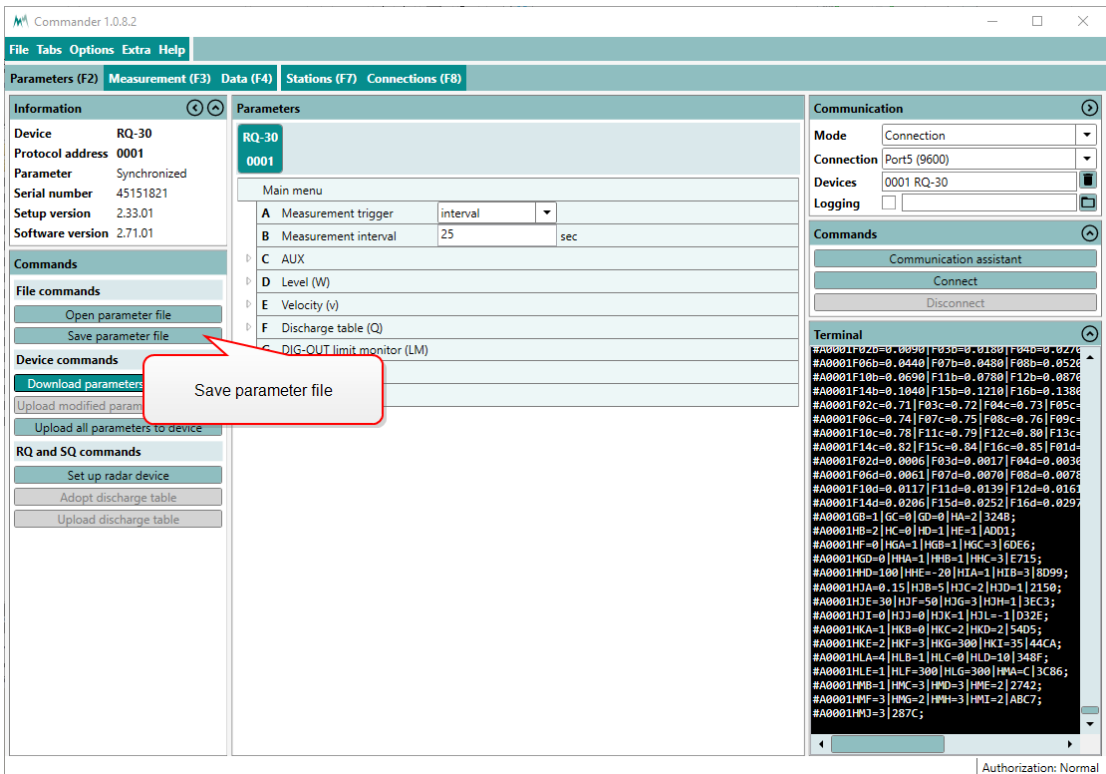

- Adapt the parameters required for your application. Changed values are displayed with a pink background.

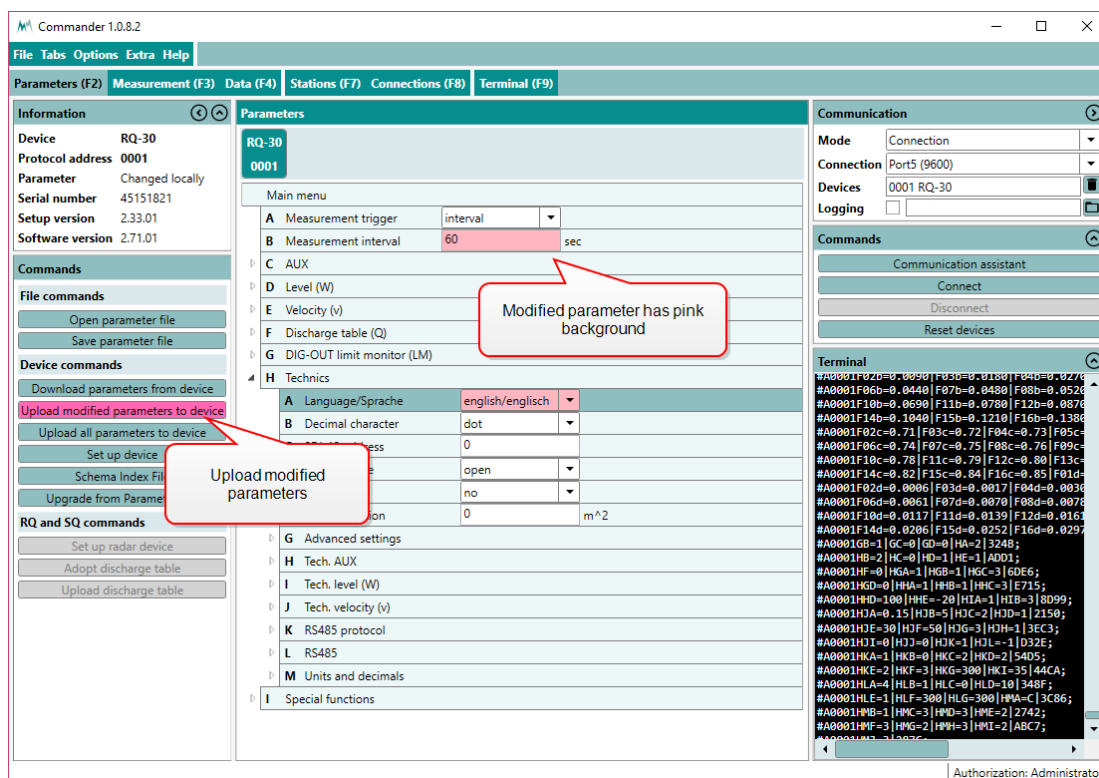

- Send the modifications to the USH-9 by clicking **Upload modified parameters to device**. Upon successful upload the pink backgrounds disappear again.

10.2 Configuration with a terminal program

The Commander software ships with an integrated terminal program. However, communication with the USH-9 can be performed with any terminal program.

Follow the steps below to modify the configuration parameters of the USH-9:

- Establish a connection between your PC and the USH-9.
- In the terminal window enter three question marks (???) in quick succession. The main parameter menu is displayed in response.

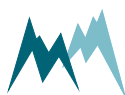

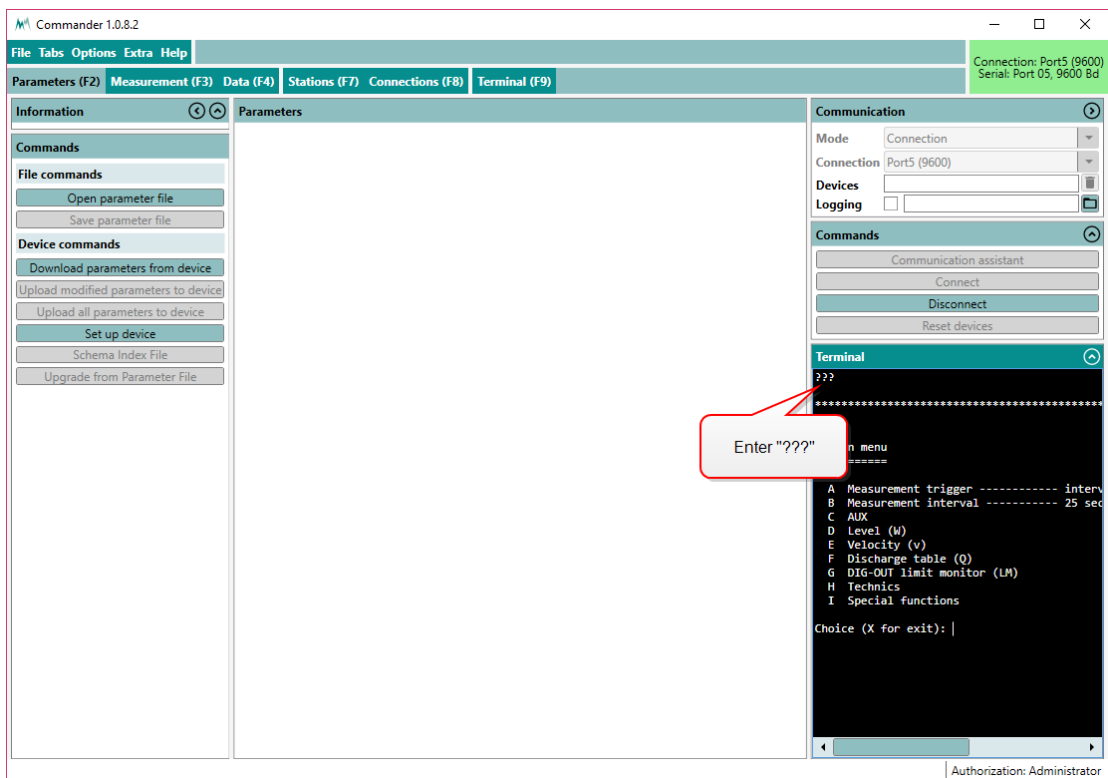

 **NOTE** As an unwanted switching into the menu mode has to be avoided the timing of the three question marks ??? is very restrictive and must never be finished with Return/Enter. This is especially important for command line tools, which may automatically send a closing "Carriage return".

3. Read or modify the required parameters: The menu items can be selected by entering the letter assigned to each item. Upon selection a submenu is opened or the selected parameter is displayed with its unit. Changes to values are confirmed with **Return/Enter** or discarded with **Esc**. Menus are closed with **X**. After closing the main menu with **X** the sensor performs an initialization.

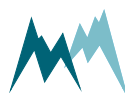

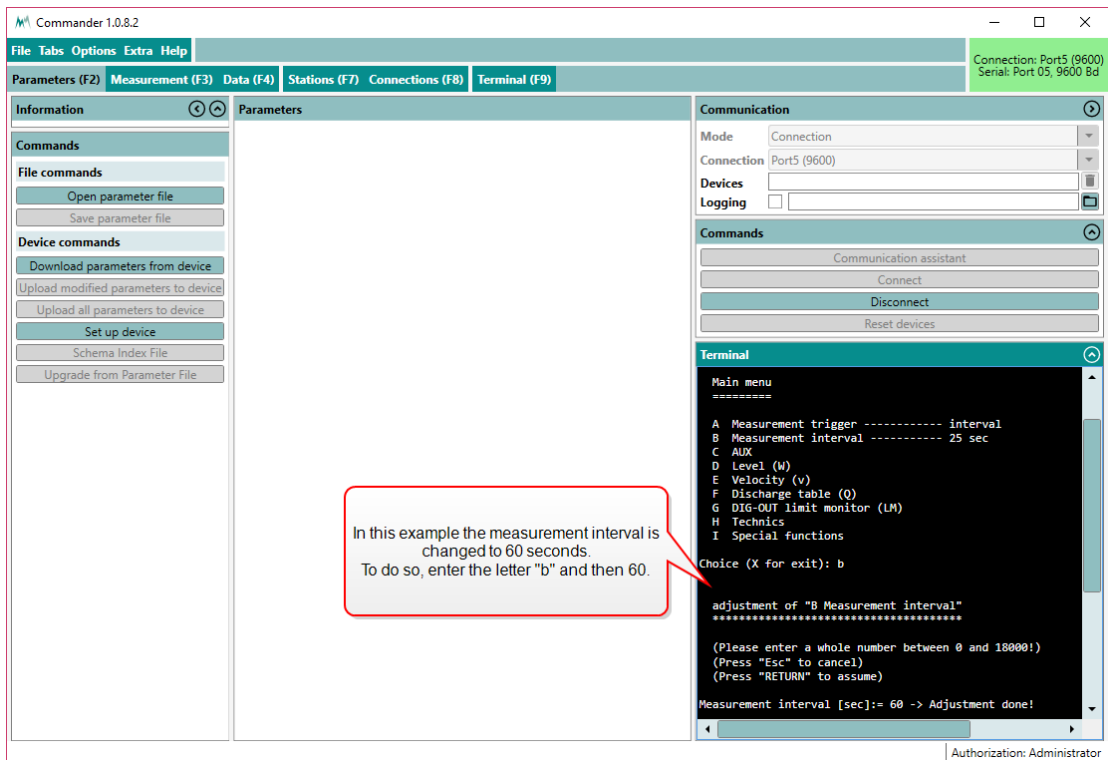

10.3 Configuration errors

10.3.1 Conflict messages

During configuration via RS-485, the USH-9 may return conflict messages after one or more parameters have been changed and uploaded to the device. An example is shown in Figure 6.

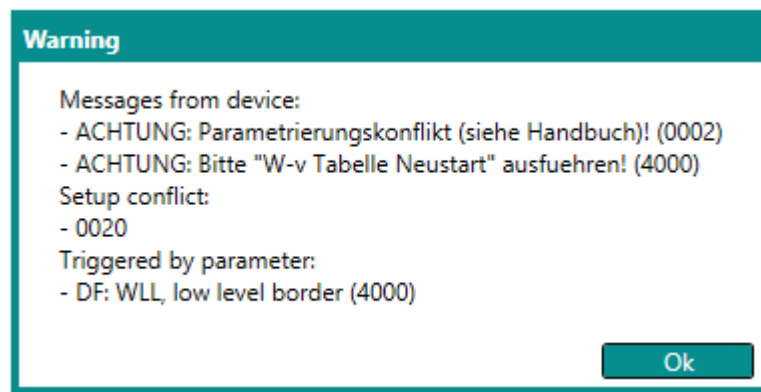
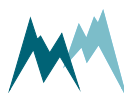

Figure 6 Conflict message





ATTENTION If a conflict occurs, invalid settings are replaced automatically with valid values. Verify the values of the conflicting parameters and adapt them if needed!

Parameter conflict

A parameter conflict message as listed below is returned if the value of a parameter conflicts with another parameter setting.

Parameter	Comment
Application	If this parameter is set to <i>Snow</i> , the selection of <i>IOUT2, function</i> should be <i>status, snow settling</i> or <i>status, snow</i> .
IOUT2, function	If Application is set to <i>Snow</i> , the selection of <i>IOUT2, function</i> should be <i>status, snow settling</i> or <i>status, snow</i> . If this is not the case, <i>IOUT2, function</i> is changed to <i>off</i> .

Table 3: Parameter conflict messages

Setup conflict

A setup conflict message as listed below is returned if a modified setup with conflicting parameters is loaded onto the USH-9.

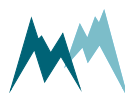

Conflict code	Parameter	Comment
0001	Max. measurement distance	Must be in the range 1'000 ... 10'000 mm. If the value is outside this range, it is set to the range limit in the selected unit.
0002	Maximum standard deviation	Must be in the range 20 ... 500 mm. If the value is outside this range, it is set to this limit in the selected unit.
0004	RoC, max. at precip. (./h)	This parameter is always set to a value equal or higher than Rate of change, maximum (./h) . If RoC, max. at precip. (./h) and Rate of change, maximum (./h) are equal, the rate of change filter is not dependent on precipitation anymore.
0008	OP, measurement output	If Output protocol (OP) is set to <i>Modbus</i> , this parameter is set to <i>just per command</i> , as Modbus does not support pushing of data.
0010	Measurement Interval	If the value is shorter than Measurement duration + 2 seconds, it is set to Measurement duration + 2 seconds. This setting ensures that the data output is not shifted to the next measurement cycle.

Table 4: Setup conflict messages

10.4 What do I need to configure?

When first setting-up a USH-9 at a measurement site, the parameters described below may need to be adapted.

10.4.1 General settings

Measurement trigger

Measurements of the USH-9 sensor can be triggered in the following ways:

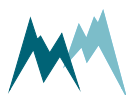

Option	Description
Interval (default)	Measurements are initiated in a specified interval.
TRIG input	Measurements are triggered by the positive edge of a DC-voltage signal applied to the TRIG input (low: 0 ... 0.6 V, high: 2.2 ... 28 V, min. pulse width: 30 ms)
SDI-12/RS-485	Measurements are externally triggered by commands via RS-485 or SDI-12 from ,e.g. a data logger.
all allowed	Measurement is triggered by all options mentioned above.



NOTE The USH-9 delays analog data acquisition by 200 ms. If *TRIG input* is used to initiate a measurement and if the measurement is acquired via the sensors analog output, the data must be requested with a delay of min. 200 ms after the trigger has been sent. This ensures that the analog measurement has sufficiently stabilized .

Measurement Interval

An internal measurement interval can be set for the USH-9. If selected in menu item [Measurement trigger](#), measurements are performed in the defined interval. However, a measurement is always completed before a new one is initiated.



NOTE [Measurement duration](#) always overrules [Measurement Interval](#), i.e., measurements are always completed before a new one is started!

Language/Sprache

The menu language.

Decimal character

The character used as decimal separator in the values of the settings and in serial data strings.

Units and decimals

The units and number of decimal digits. These have to be set prior to all other settings as all values are saved internally in this format.

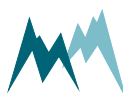



ATTENTION If units or decimals are changed, related parameters may need to be adjusted.

Output protocol (OP)

The type of the serial output protocol. The following options are available:

Option	Description
Sommer (default)	Sommer protocol; data values are returned with an index starting at 1
Standard	Standard protocol; data values are returned without an index
MODBUS	Modbus protocol

OP, information

The main measurement values are always included in the data output string. Additionally, special and analysis values can be included. See [Which data do I get?](#) for details.

10.4.2 Level/Distance measurement

Measurement duration

The duration of a single measurement. During this time the ultrasonic signal is recorded and the distance to the monitored surface calculated. Generally, a measurement duration of 6 s is recommended.



NOTE [Measurement duration](#) always overrules [Measurement Interval](#), i.e., measurements are always completed before a new one is started!

Level/distance test

Function to test the level/distance measurement. Initiates a measurement and returns the current distance and level.



Adjust level

Function to adjust the level measurement of the USH-9 to the actual level. It first initiates a measurement and then requests the actual level.

Distance to zero level

The distance between the sensors lower edge and the ground surface, e.g. lowest point of river bed, ground without snow.



ATTENTION The USH-9 must be mounted perpendicular to the ground surface!

Application

The USH-9 can be used for the following applications:

Option	Description
snow (default)	Settings for snow applications are active. These settings include precipitation detection and snowfall limits (see Status limits and Advanced settings). Rate of change filtering (RoC, max. without precip. (./h) and RoC, max. at precip. (./h)) is active.
water	Settings for water application are active. Precipitation detection and rate of change filtering (RoC) are deactivated.
others	Settings for water and snow applications are inactive. Used for generic level/distance measurements. A constant rate of change filter (Rate of change, maximum (./h)) is active.



ATTENTION By default the USH-9 is configured for snow-depth measurements. If the instrument is used for water level monitoring, adapt its configuration as described in [How do I configure the USH-9 for water level measurements?](#).

Moving filter, duration

Every level/distance measurement is stored internally in a buffer for filtering. This setting defines the length of the time window of which the data are stored in the buffer. If the buffer is full, the

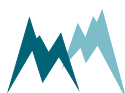

oldest value is replaced by the most recent one.

The figure below illustrates the default moving filter duration of 180 seconds. While a [Measurement Interval](#) of 90 seconds embraces two measurement values, an interval of 45 seconds includes 4 values.

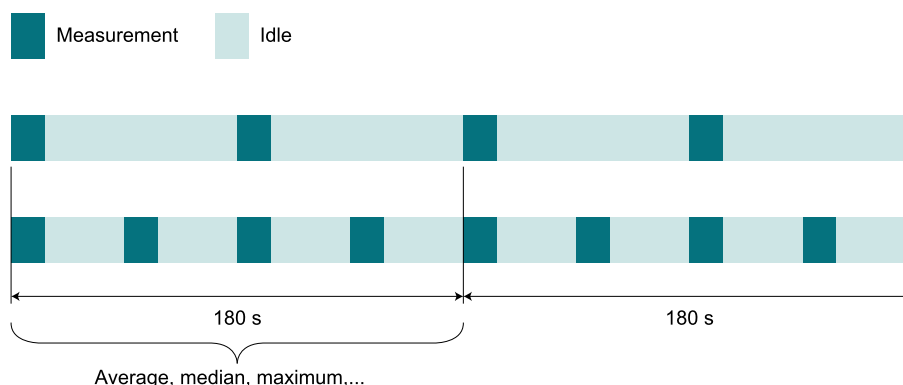

Moving filter, type

Defines the filter that is applied to the acquired data; see [Moving filter, type](#) for the available options.

10.5 How do I configure the USH-9 for snow measurements?

By default the USH-9 is configured for snow applications. This can be checked in the setting [Application](#), which is set to *snow*.

If the USH-9 needs to be re-configured for snow applications, set

1. [Application](#) to *snow*,
2. [Moving filter, duration](#) to 180 seconds, and
3. [Moving filter, type](#) to elim. all spikes.

Settings 2 and 3 may be adapted to values better suited for your application. See [Parameter definitions](#) for more details.



ATTENTION Make sure to upload the modified parameters to the USH-9 and test the new settings as described in [How do I test the USH-9 indoors?](#).

10.6 How do I configure the USH-9 for water level measurements?

If the USH-9 is used for water level monitoring, set

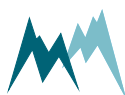

1. [Application](#) to *water*,
2. [Moving filter, duration](#) to 0 seconds, and
3. [Moving filter, type](#) to median.

Settings 2 and 3 may be adapted to the flow conditions of your river or channel. See [Parameter definitions](#) or more details.



ATTENTION Make sure to upload the modified parameters to the USH-9 and test the new settings as described in [How do I test the USH-9 indoors?](#).



11 Serial communication

11.1 What are the options?

Serial data communication with the USH-9 can be performed by

- RS-485
- Modbus
- SDI-12

11.2 Which data do I get?

The measurement values returned by the USH-9 are arranged in a fixed sequence and identified by an index. They are divided into three groups and can be selected in [OP, information](#).

11.2.1 Main values

Index	Measurement value	Unit	Description
01	Level	mm	
02	Distance	mm	
03	Temperature	°C	Air temperature
04	Status	-	Status of snow cover, 3-digit number: 100 snowfall 010 snow cover emerges 001 snow-depth limit exceeded Combinations of the above are possible, see for details

Table 5: Main values

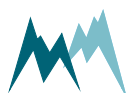

11.2.2 Special values

Index	Measurement value	Unit	Description
05	Precipitation	-	Dimensionless value representing precipitation type and intensity. Its range is 0 to 1000, where 1000 is the most intensive precipitation that can be expected. The value strongly depends on the type of precipitation: wet snow that falls in large flakes gives high values, cold, small flakes give lower values even though snowfall can be intense. Rain generally gives lower values than snow. The precipitation value is used to optimize the rate of change filter (RoC) that is affected by reflections of precipitation. It cannot substitute a rain gauge.
06	Signal quality	dB	SNR (signal to noise ratio)
07	Std. deviation	mm	Standard deviation of the measured level
08	Supply voltage	V	Power supply voltage

Table 6: Special values

11.2.3 Analysis values

Index	Measurement value	Unit	Description
09	Signal focus	dB	Diagnostic variable
10	Signal strength	dB	Diagnostic variable
11	Half-value width	%	Diagnostic variable
12	Noise ratio 50	%	Diagnostic variable
13	Noise ratio 85	%	Diagnostic variable



Index	Measurement value	Unit	Description
14	Echo amp.	-	Diagnostic variable
15	Var. 1	-	Diagnostic variable
16	Var. 2	-	Diagnostic variable
17	Var. 3	-	Diagnostic variable
18	Dist. max. echo	mm	Diagnostic variable
19	Dist. last echo	mm	Diagnostic variable
20	Distance 0 C	mm	Diagnostic variable
21	Case temperature	°C	Diagnostic variable
22	Error code ¹	-	Diagnostic variable

Table 7: Analysis values

11.2.4 Exception values

Measurement data may be returned with the following exception values:

Value	Description
9999.998	Initial value: No measurement has been performed yet (position of decimal character is irrelevant).
9999.997	Conversion error: Caused by a technical problem (position of decimal character is irrelevant)
9999999	Positive overflow
-9999999	Negative overflow

Table 8: Exception values

¹see [Device Errors](#) for details

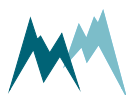

11.3 RS-485

11.3.1 What is it?

RS-485 is a serial communication method for computers and devices. It is currently a widely used communication interface in data acquisition and control applications where multiple nodes communicate with each other.¹

11.3.2 What can I do with it?

RS-485 communication is primarily used to trigger measurements and read their results. It also permits to change parameters of the USH-9.

11.3.3 How do I wire it?

The USH-9 can be connected to a data logger or a RS-485 network according to the figure below.

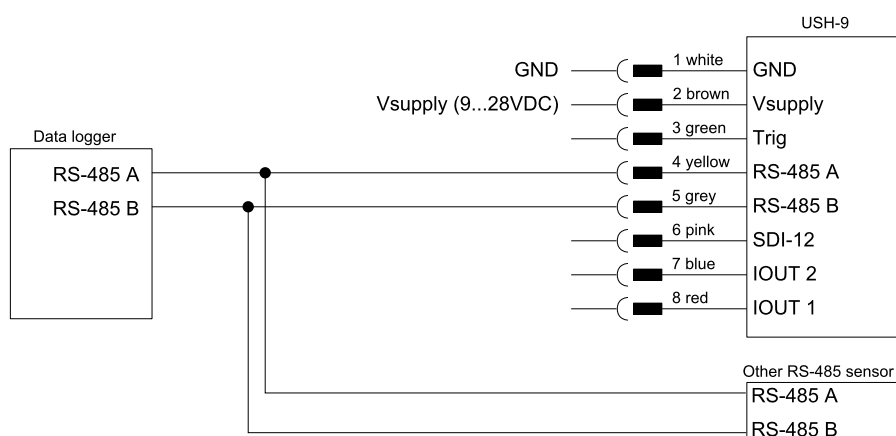

Figure 7 Wiring of the USH-9 with a data logger via RS-485

11.3.4 How do I configure it?

The USH-9 has serial RS-485 communication enabled by default. If the device is integrated into a RS-485 network or connected to a stand-alone data acquisition system, e.g. a data logger, the parameters listed in [RS-485 Protocol](#) may need to be adapted:

¹<https://www.lammertbies.nl/comm/info/RS-485.html>

RS-485 Port

By default the serial port of the USH-9 is configured as follows:

Baud rate	9600
Data bits	8
Parity	none
Stop bits	1
Flow control	none

System key and device number

The system key and device number are used to identify a USH-9 in a bus system. This is essential if multiple devices (USH-9 and data loggers) are operated within the same system.

System key

The system key separates different conceptual bus systems. This may be necessary if the remote radio coverage of two measurement systems overlap. In general, the system key should be set to *00*.

Device number

The device number is a unique number that identifies a device in a bus system.

OP, measurement output

The serial data output can be triggered in the following ways:

Option	Description
just per command	The output is only requested by commands via the RS-485 or SDI-12 interface.
after measurement (default)	The serial data output is performed automatically right after each measurement.
pos. TRIG slope	The output is triggered by a positive edge of a control signal applied to the trigger input.

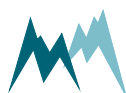



NOTE If *OP, measurement output* is set to *pos. TRIG slope*, the data are returned with a delay of 200 ms after the trigger has been set. Make sure that your data acquisition system takes account of this lag to ensure that it receives the most recent data.

Operation modes

The selected combination of measurement trigger and output time determines the following operation modes:

Pushing mode

This is the default operation mode: The measurements are triggered internally by the USH-9 and the data are returned automatically after each measurement. No external trigger is required. Set *Measurement trigger* to internal and *OP, measurement output* to *after measurement*.

Polling mode

A connected data logger triggers the measurements and the data output. Set *Measurement trigger* to TRIG input or SDI-12/RS485 and *OP, measurement output* to *just per command*.

Apparent polling

A connected data logger triggers only the measurements. The data output is performed automatically after each measurement. Set *Measurement trigger* to *TRIG input* or *SDI-12/RS485* and *OP, measurement output* to *after measurement*.

Waking-up a connected data logger

The USH-9 supports wake-up of a connected data logger that is in standby mode. Generally, this feature is only used in pushing mode and can be set under *OP, wake-up sequence*.

Sync sequence

The sync sequence is the string `UU~???` and is sent directly before a command. It is used to synchronize the receiving UART.

Prefix

The prefix is an arbitrary character; the USH-9 uses a blank. This character is sent prior to any communication. Then the time of the *OP, prefix holdback* is waited and the command is sent afterwards. With this procedure the receiving device has time to wake-up.

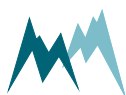

Output protocols

For data output via RS-485 different protocols are available, which can be selected under [Output protocol \(OP\)](#).

11.3.5 How is the output structured?

Data are returned in two different formats, selectable in [Output protocol \(OP\)](#):

- [Sommer protocol](#)
- [Standard protocol](#)

11.3.6 Sommer protocol

The data string of the Sommer protocol has the following format:

 **EXAMPLE** #M0001G01se01 1461|02 1539|03
25.25|04 0|3883;

Header

The header (#M0001G00se) identifies the data by system key, device number and string number.

Parameter	Format	Description
Start character	#	
Identifier	M	M identifies an output string
System key	dd	
Device number	dd	

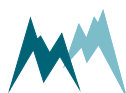

Parameter	Format	Description
Command ID	G	G defines an output string with string number
String number	dd	01 Main values 03 Special values 05 Analysis values 06 Analysis values
Command	se	se identifies automatically sent values

Table 9: Header of the Sommer protocol

Measurement value

A measurement value (02 1539 |) has a length of 8 digits and is returned together with its index. If the measurement value is a decimal number, one digit is reserved for the decimal character. Values are returned right-aligned, so blanks may occur between index and value.

Parameter	Format	Description
Index	dd	2 numbers
Value	xxxxxxxx	8 character right-aligned
Separator		

Table 10: Values in Sommer protocol

End sequence

The data string is terminated with a CRC-16 in hex format (3883) followed by an end character and <CR><LF>. The CRC-16 is described in [Sommer CRC-16](#).

Parameter	Format	Description
CRC-16	Hhhh	4-digit hex number
End character	;	
Control characters	<CR><LF>	Carriage return and Line feed

Table 11: End sequence of the Sommer protocol

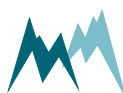

Example Sommer protocol

Main values

Main values are returned as in the following example:

✓ **EXAMPLE** #M0001G01se01 1461|02 1539|03
25.25|04 0|3883;

#M0001G01se	Header with system key 00, device number 01 and string number 01
01 1461	Level
02 1539	Distance
03 25.25	Temperature
04 0	Status
3883;	Closing sequence

Table 12: Main values in Sommer protocol

Special values

Special values are returned as in the following example:

✓ **EXAMPLE** #M0001G03se05 921|06 49.7|07
2|08 11.76|D537;

#M0001G03se	Header with system key 00, device number 01 and string number 03
05 921	Precipitation
06 49.7	Signal quality
07 2	Std. deviation
08 11.76	Supply voltage
D537;	Closing sequence

Table 13: Special values in Sommer protocol



Analysis values

Analysis values are returned as in the following example:

```

✓ EXAMPLE
#M0001G05se09      33.8|10      43.8|11      34|12
43.23|13      13.51|14      9|15      -28.6|7E66;

#M0001G06se16      1|17      2920|18      1565|19
5578|20      1472|21      25.70|22      0.00|0E53;
    
```

#M0001G05se	Header with system key 00, device number 01 and string number 05 for the analysis values 9 to 15
0 933.8	Signal focus
10 43.8	Signal strength
11 34	Half value width
12 43.23	Noise ratio 50
13 13.51	Noise ratio 85
14 9	Echo amp.
15 -28.6	Var. 1
7E66;	Closing sequence
#M0001G06se	Header with system key 00, device number 01 and string number 06 for the analysis values 16 to 22
16 1	Var. 2
17 2920	Var. 3
18 1565	Dist. max. echo
19 5578	Dist. last echo
20 1472	Distance 0 C
21 25.70	Case temperature

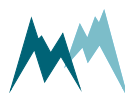

22	0.00	Error code
0E53;		Closing sequence

Table 14: Analysis values in Sommer protocol

11.3.7 Standard protocol

The data string of the Standard protocol has the following format:

	EXAMPLE M_0001	1461	1359	25.38	0
---	-----------------------	------	------	-------	---

Header

The header (M_0001) identifies the data by system key and device number.

Parameter	Format	Description
Identifier	X_	M_ Measurement values S_ Special values V_ Analysis values
System key	Dd	
Device number	Dd	

Table 15: Header of the Standard protocol

Measurement values

Measurement values are returned in sequence and are separated by a blank. A measurement value has a length of 8 digits. If the measurement value is a decimal number, one digit is reserved for the decimal character. Values are returned right-aligned, so additional blanks may be returned between values.

Parameter	Format	Description
Separator	[blank]	blank
Value	xxxxxxxx	8 character right-aligned

Table 16: Values in Standard protocol

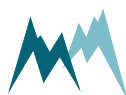

End sequence

The data string is terminated with <CR><LF>.

Example Standard protocol

Main values

Main values are returned as in the following example:

 EXAMPLE M_0001 1461 1359 25.38 0	
M_0001	Header with identifier for measurement values
1461	Level
1359	Distance
25.38	Temperature
0	Status

Table 17: Main values in Standard protocol

Special values

Special values are returned as in the following example:



 EXAMPLE S_0001 1004 46.5 2 11.69	
S_0001	Header with identifier for measurement values
1004	Precipitation
46.5	Signal quality
2	Std. deviation
11.69	Supply voltage

Table 18: Special values in Standard protocol

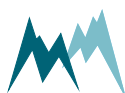

Analysis values

Analysis values are returned as in the following example:

	EXAMPLE	v_0001	39.2	43.8	30	42.85
		13.56	9	-25.1	1	3023
		5543	1473	25.50	0.00	1563

v_0001	Header with identifier for analysis values
39.2	Signal focus
43.8	Signal strength
30	Half value width
42.85	Noise ratio 50
13.56	Noise ratio 85
9	Echo amp.
-25.1	Var. 1
1	Var. 2
3023	Var. 3
1563	Dist. Max. echo
5543	Dist. Last echo
1473	Distance 0 C
25.50	Case temperature
0.00	Error code

Table 19: Analysis values in Standard protocol

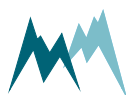

11.3.8 Which commands are available?

Command structure

The structure of serial commands and answers (#W0001\$mt|BE85;) is described in the following table:

Parameter	Format	Description
Start character	#	
Identifier	X	<p>W USH-9 returns a confirmation on receipt. This command type demands a closing sequence with a valid CRC-16.</p> <p>S USH-9 does not acknowledge the receipt of the command. This command type demands no closing sequence and therefore no CRC-16.</p> <p>R USH-9 returns the requested measurement value or parameter. This command type demands a closing sequence with a valid CRC-16.</p> <p>T Write a volatile setting and receive a confirmation</p> <p>A Answer of device to read or write command</p>
System key	dd	
Device number	dd	
Command	xxx	See Commands
Separator		
CRC-16	hhhh	4-digit hex number
End character	;	

Table 20: Structure of RS-485 commands and answers

Commands

The following commands can be used with the USH-9:

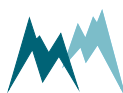

Command	Description
\$mt	Trigger a measurement
\$pt	Return measurement values
XX	Read a parameter with identifier XX
XX=xxxx	Write a parameter with identifier XX and the value xxx

Table 21: List of RS-485 commands

Trigger a measurement

The command \$mt triggers a complete measurement sequence as in the following example:

 **EXAMPLE** #W0001\$mt|BE85; Answer: #A0001ok\$mt|4FA9;

Read a parameter value

Read measurement interval (in the example below the menu item B):

 **EXAMPLE** #R0001B|228E; Answer: #A0001B=300|F8B3;

Request a complete data string

The command \$pt requests a data string as in the following example:

 **EXAMPLE** #S0001\$pt| Answer: none

The data string is returned as soon as the USH-9 has processed the command.

Request a single measurement value

The reading command R together with the index of the requested measurement returns a single measurement value. In the following example the measurement value with index 01 (in this example a water level) is requested:

 **EXAMPLE** #R0001_010cv|EA62;

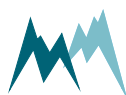



Answer: #A0001ok_010cv1461 | 07EB;

11.3.9 Sommer CRC-16

The CRC-16 (cyclic redundancy check) used in data transmission of Sommer devices is based on the ZMODEM protocol. When data are exchanged between two devices the receiving device calculates the CRC-value. This value is compared to the CRC value sent by the other device to check if the data were transmitted correctly. Please refer to technical literature or contact Sommer for calculation of CRC-16 values.

11.4 SDI-12

11.4.1 What is it?

SDI-12 (Serial Data Interface at 1200 Baud) is a serial data communication standard for interfacing multiple sensors with a single data recorder. For a detailed description on SDI-12 communication please refer to www.sdi-12.org.

11.4.2 What can I do with it?

The USH-9 listens to standard SDI-12 commands as listed in the SDI-12 specifications of version 1.3, e.g., to trigger a measurement or retrieve measurement results. Additionally, a set of extended SDI-12 commands is implemented in all SOMMER sensors for instrument configuration.

11.4.3 How do I wire it?

The USH-9 can be connected to a data logger via SDI-12 according to the figure below.

SDI-12 uses a shared bus with a ground wire, a data wire (indicated as SDI-12) and an optional +12 V wire.



NOTE The connection with the 12 V power supply is optional and depends on the connected SDI-12 master device (typically a data logger).



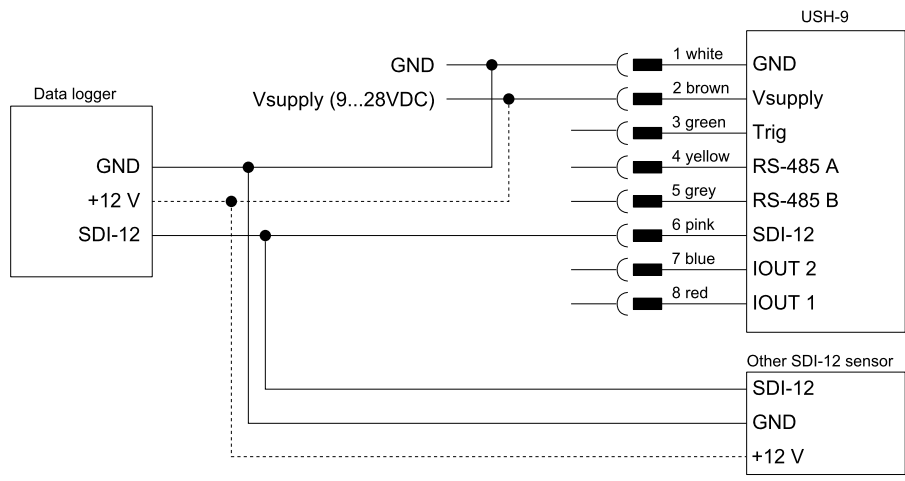

Figure 8 Wiring of the USH-9 with a data logger via SDI-12

11.4.4 How do I configure it?

The USH-9 has SDI-12 communication enabled by default. If the device is connected to a data acquisition system, e.g. data logger, and if multiple SDI-12 devices are connected to the same bus, the [SDI-12 address](#) may need to be adapted.

11.4.5 How are commands structured?

A standard SDI-12 command starts with the sensor address and ends with an exclamation mark, e.g., 0M!

The answer from the SDI-12 device is a string containing the sensor address, the requested data and a terminating carriage return/line feed, e.g.,

EXAMPLE 0+2591+706+25.53+0<CR><LF>

11.4.6 Which commands are available?

The following tasks can be performed with standard and extended SDI-12 commands. Extended SDI-12 commands are non-standard commands implemented by SOMMER to enable device configuration via SDI-12.

NOTE After any changes, the settings have to be adopted with the command `aXW_ts|!`, with `a` the sensor address.

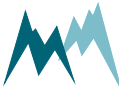

Identify device

The identification of a SDI-12 device is requested with the command `aI!`, with `a` the sensor address.



EXAMPLE

`0I!` Answer `013Sommer USH 140r90 USH-9 <CR><LF>`

The answer contains the following information:

0	SDI-12 address
1	SDI-12 version prior to the point
3	SDI-12 version after the point
Sommer	Description of the company (6 characters and 2 blanks)
USH	Description of the firmware (5 characters and 2 blanks)
140r90	Firmware version (6 characters and 2 blanks)
USH-9	Device designation (max. 13 characters)

Acquire measurements

To acquire a measurement from a sensor, two individual SDI-12 commands – trigger a measurement and request measurement values – need to be sent.



EXAMPLE

`0M!` Answer: `00084<CR><LF>` and `0<CR><LF>` after 8 seconds

`0D0!` Answer: `0+2591+706+25.53+0<CR><LF>`

The first values in the response to the `aDn!` command is the sensor address.

Trigger measurement

The command `aM!` with sensor address `a` triggers a measurement as in the example below.

The response states the measurement duration and the number of measurement values (see example below). After completion of the measurement, the device will return an additional `a<CR><LF>`, with `a` the sensor address.



EXAMPLE

`0M!` Answer: `00084<CR><LF>` and `0<CR><LF>` after 8 seconds

The answer contains the following information:

0	SDI-12 address
008	Duration of the measurement in seconds

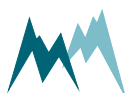



4

Number of measurement values

Request results

After each measurement, results are requested with the command `aDn!`, with `a` the sensor address and `n` the index of the returned data string.



EXAMPLE `0D0!` Answer: `0+2591+706+25.53+0<CR><LF>`

The leading `0` of the response is the sensor address.

Generally, the command `aD0!` is sufficient to request up to 9 measurement values. If more than 9 values need to be read, or if the values are returned in groups, the commands `aD1!`, `aD2!`,... may need to be issued after `aD0!`. For example, if a measurement returns 8 values in two groups of 4, the commands `aD0!` and `aD1!` need to be issued to receive all values.

Acquire continuous measurements

If the SDI-12 device is operating in continuous measurement mode (not polled by SDI-12), the command `aR0!` will request and return the current reading of the sensor. The values within the data string follow the order listed in the measurement table. The first values in the response to the `aRn!` command is the sensor address.



EXAMPLE
`0R0!` Answer: `0+2591+706+25.53+0<CR><LF>`

If more than 9 values need to be read, or if the values are returned in groups, the commands `aR1!`, `aR2!`,... may need to be issued after `aR0!`. For example, if a measurement returns 8 values in two groups of 4, the commands `aR0!` and `aR1!` need to be issued to receive all values.

Configure device

The configuration parameters of a SOMMER sensor are read with the command `aXRpp!` and written with the command `aXWpp=vvv!`, with `a` the sensor address, `pp` the parameter identifier and `vvv` the value of the parameter.

Read and write a parameter



EXAMPLE
Reading of measurement interval (in this example menu item B)

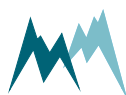



0XRB | ! Answer: 0B=300 | <CR><LF>

Setting of measurement interval to 60 s (in this example menu item B)

0XWB=60 | ! Answer: 0B=60 | <CR><LF>

Read and write a parameter with options

Changing the measurement trigger (in the following example menu item A) from *interval* to *SDI-12/RS485*:



EXAMPLE

0XRA | ! Answer: 0A=1 | <CR><LF>

0XWA=3 | ! Answer: 0A=3 | <CR><LF>

Read and write a parameters of a table

Some SOMMER sensors are equipped with multiple transducers and their settings are listed in a table (see example below). A value within such a table is addressed by its row-index (01, 02 ...) and column-index (A, B ...). A corresponding SDI-command has the following format:



EXAMPLE

In this example of a snow scale the value in row 01 and column B of the parameter D-D-E is changed to -1.4.

0XWDDE01B=-1.4 | ! Answer: 0DDE01b=-1.4 | <CR><LF>

	Identifier	offset zero kg	gain	zero default kg	gain default
01	Load Cell 1	-1.4	0,997787	0,000	0,997787
02	Load Cell 2	0,000	0,997787	0,000	0,997787
03	Load Cell 3	0,000	0,997787	0,000	0,997787
04	Load Cell 4	0,000	0,997787	0,000	0,997787

Adopt settings

Some settings need to be adopted with the command `aXW_ts | !`, with a the sensor address. It is recommended to issue `aXW_ts | !` after each configuration change.

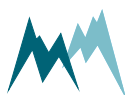

11.5 Modbus

11.5.1 What is it?

Modbus is a serial communication protocol used for transmitting information over serial lines between electronic devices. The device requesting the information is called the Modbus Master and the devices supplying information are Modbus Slaves. In a standard Modbus network, there is one Master and up to 247 Slaves, each with a unique Slave Address from 1 to 247. The Master can also write information to Slaves.

Modbus has become a standard communication protocol in industry, and is now the most commonly available means of connecting industrial electronic devices. It is often used to connect a supervisory computer with a remote terminal unit (RTU) in supervisory control and data acquisition (SCADA) systems. Versions of the Modbus protocol exist for serial lines (Modbus RTU and Modbus ASCII) and for Ethernet (Modbus TCP).¹

11.5.2 What can I do with it?

Modbus-communication with USH-9 allows reading of measurement values and device information by a Modbus master. Additionally, the basic RS-485 port settings can be written to the USH-9.

11.5.3 How do I wire it?

For Modbus communication the USH-9 is wired according to the table below.

Modbus	Connector MAIN	Connection wire	Description
Common	Pin 1	White	GND
D1 - B/B	Pin 4	Yellow	RS-485 A
D0 - A/A	Pin 5	Grey	RS-485 B

Table 22: Connection to a Modbus



NOTE If the USH-9 is operated with multiple Modbus devices within the same network, termination resistors may be required. Please contact Sommer Messtechnik for details.

¹<http://www.simplymodbus.ca/FAQ.htm>

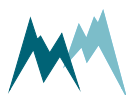

11.5.4 How do I configure it?

Follow the instructions below to change the communication of a Sommer-device (in this example a RG-30) to Modbus:

1. Connect the USB to RS-485 converter to the data cable of the Sommer-device and a USB port on your PC.
2. Connect the sensor to a power supply with the specified rating.
3. Start the Commander software on your PC.
4. Establish a connection to the Sommer-device.
5. Download the sensor's parameters in the **Parameters (F2)** tab and save the parameter list on your PC.

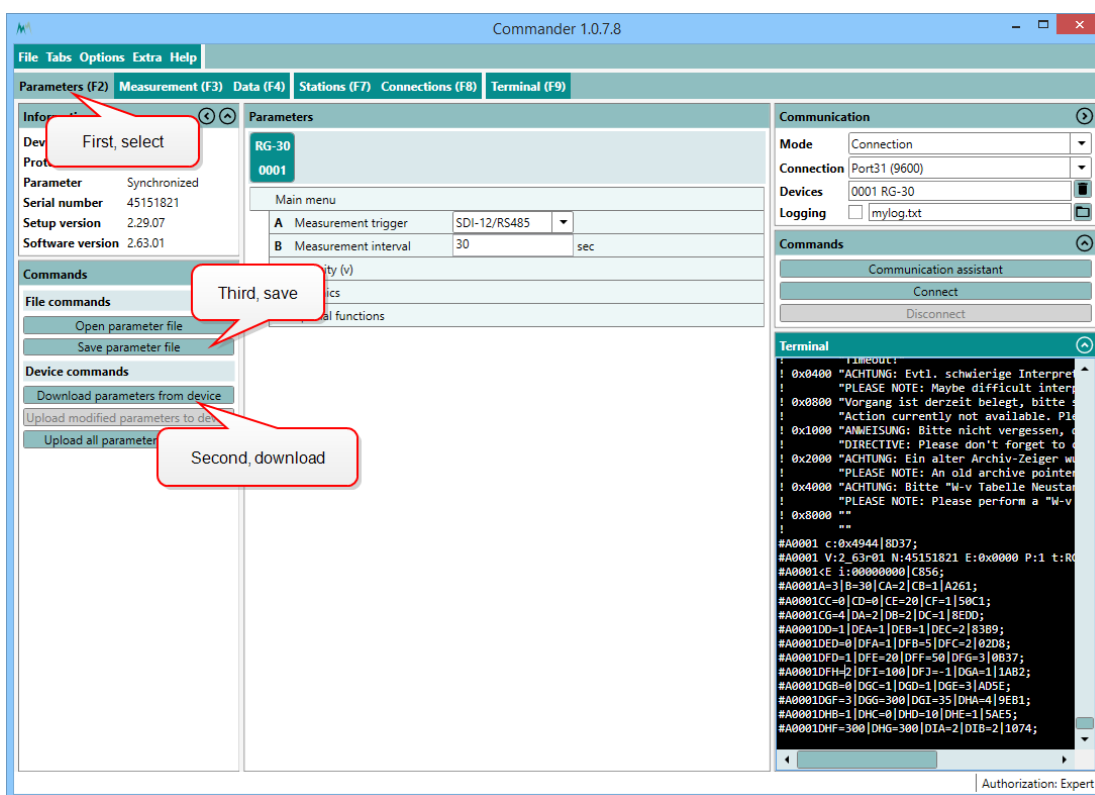

6. In the parameter list navigate to Technics and open the menus **RS-485 protocol** and **RS485** and take a screenshot of the associated parameters. This and the previous step are helpful if you need to switch back to the standard communication mode at a later time.



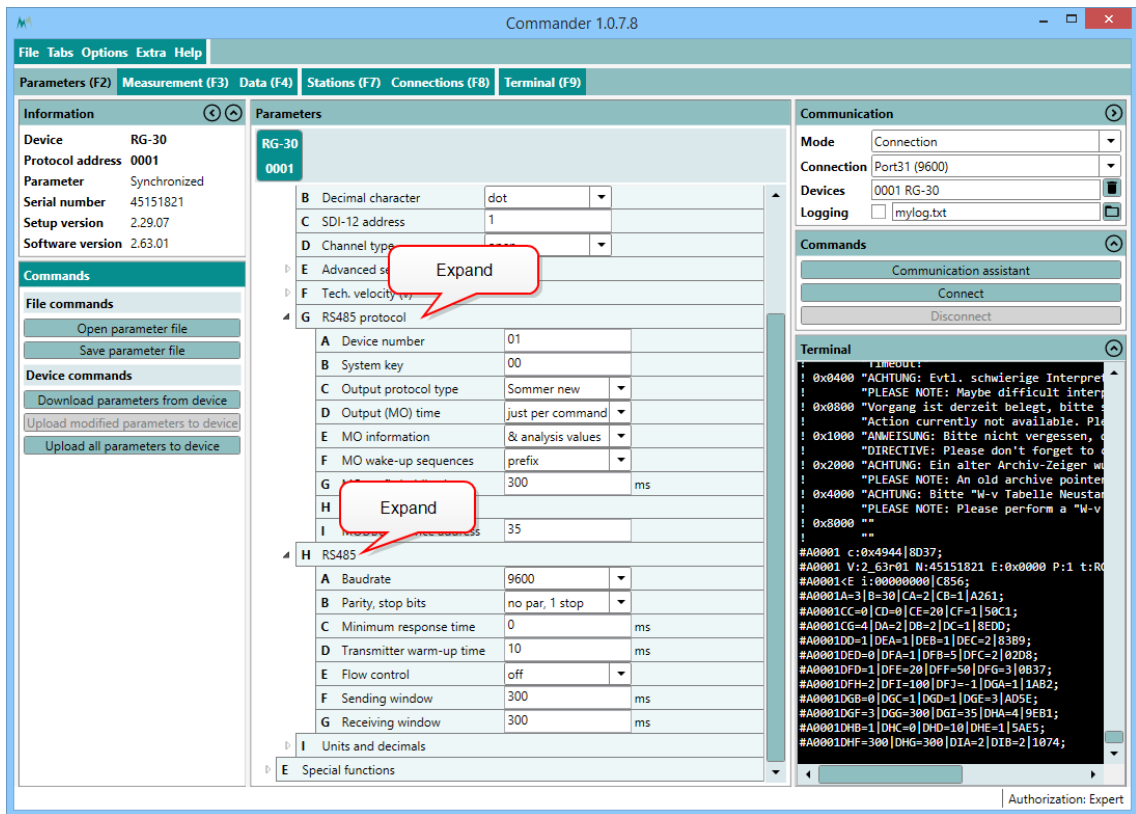

7. Set **Measurement trigger** to one of the following options:
 - A. *Interval*, if measurements are triggered internally by the device.
 - B. *SDI-12/RS-485*, if measurements are triggered by SDI-12.
 - C. *TRIG input*, if measurements are triggered by a trigger input.
 - D. *all allowed*, if measurements are triggered by one of the previous options.



NOTE Modbus cannot trigger measurements! Make sure to use the trigger option suitable for your application!

8. Verify that the connection to the Sommer-device is active and click into the Terminal window. Type `???` to enter the sensor-menu.



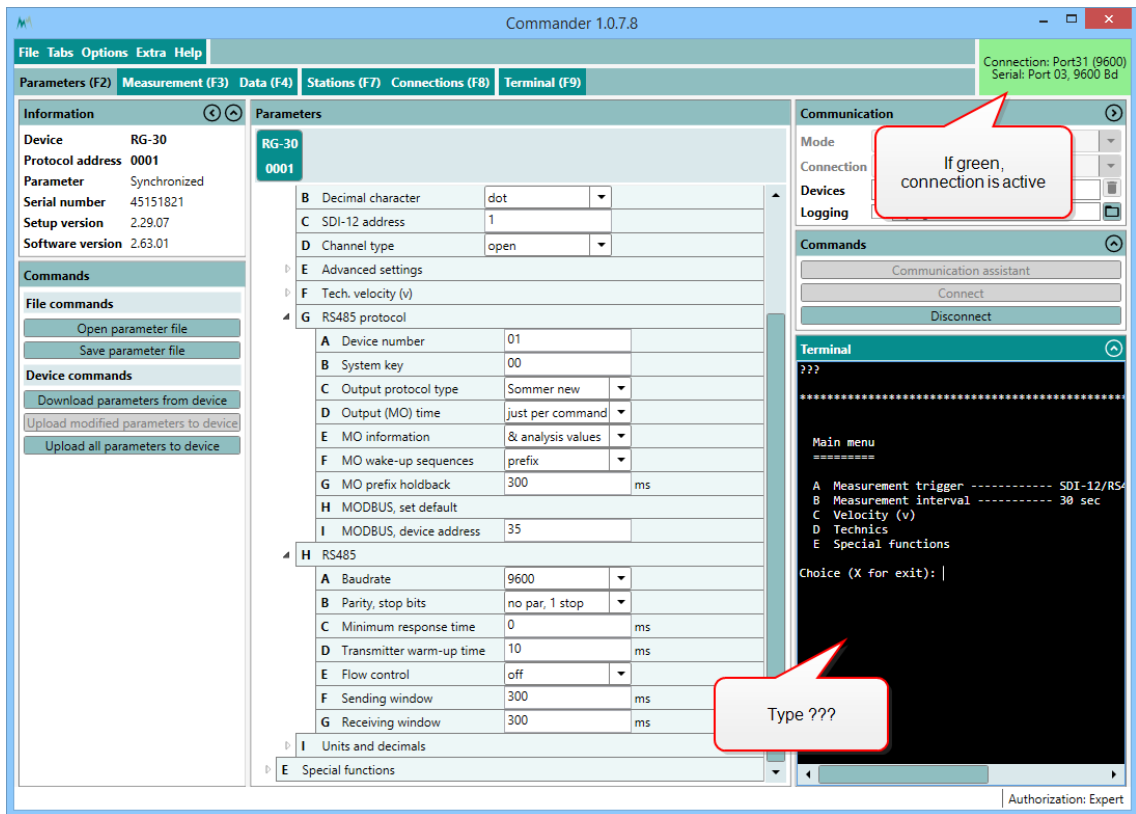

- Navigate to *RS485 protocol* and select *MODBUS, set default...* Please note, that the index-letters might be different for your Sommer-device!

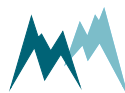

```

Terminal
Main menu
=====
A Measurement trigger ----- SDI-12/RS485
B Measurement interval ----- 30 sec
C Velocity (v)
D Technics
E Special functions

Choice (X for exit): d

Technics
=====
A Language/Sprache ----- english/englisch
B Decimal character ----- dot
C SDI-12 address ----- 1
D Channel type ----- open
E Advanced settings
F Tech. velocity (v)
G RS485 protocol
H RS485
I Units and decimals

Choice (X for exit): g

RS485 protocol
=====
A Device number
B System key --
C Output protoc
D Output (MO) t
E MO informatio
F MO wake-up se
G MO prefix holdback ----- 100 ms
H MODBUS, set default...
I MODBUS, device address ----- 35

Choice (X for exit): |
    
```

Enter the letter of 'MODBUS, set default ...'

10. Acknowledge the safety-note.

```

Start up testmode: 0x09

MODBUS, set default
AAAAAAAAAAAAAAAAAAAA

PLEASE NOTE: This process changes to 19200 baud, even parity, ...
DIRECTIVE: Please don't forget to change the serial counterpart too!

Are you sure?

(Press "RETURN" to assume)
(Press "Esc" to cancel)
    
```

Press Enter

11. After completion the following message will be displayed:

```

=> Testmode finished!

=> DIRECTIVE: Please don't forget to change the serial counterpart too!
    
```

12. Enter X until you get back to the main menu. The Sommer-device is now restarted and available for Modbus-communication. As the connection-parameters have been changed to Modbus, the connection to the sensor is lost. Press Disconnect for completion.

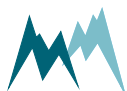

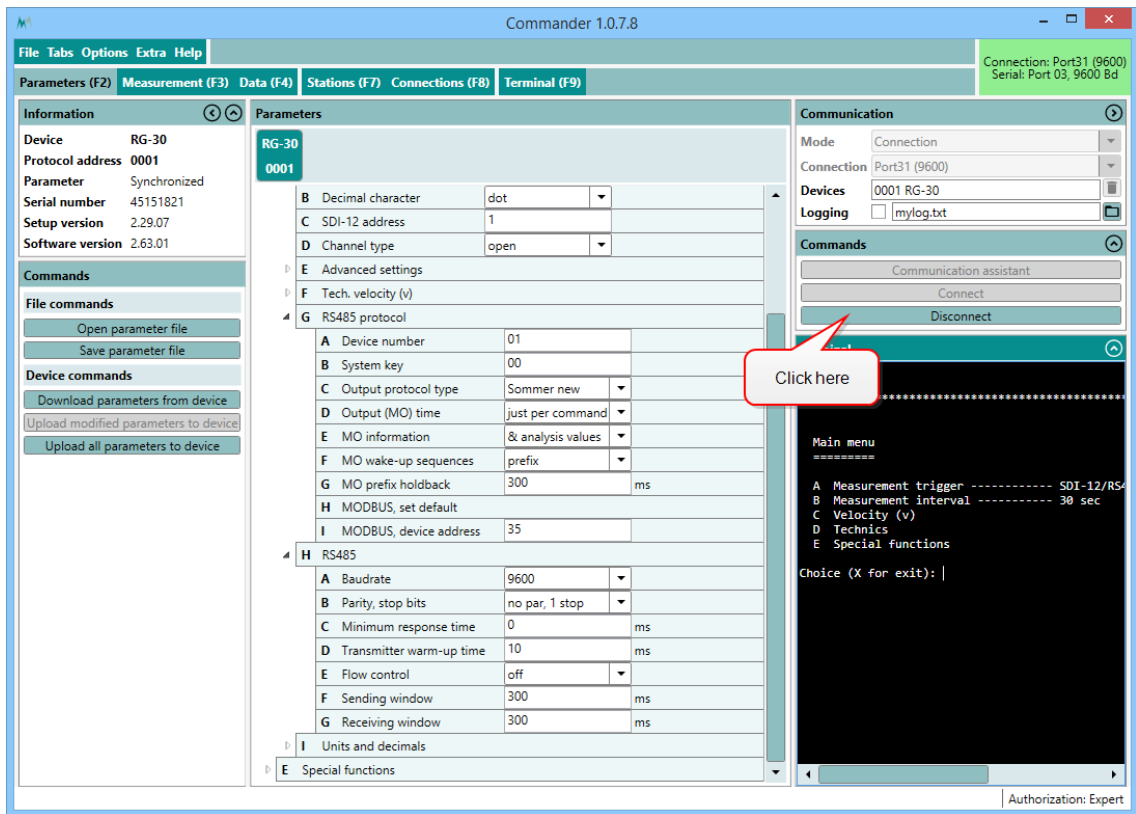

NOTE

By switching communication to Modbus with MODBUS, set default the following parameters are changed:

Parameter	Modbus setting
OP, measurement output	just per command
Output protocol (OP)	Modbus
MODBUS, device address	35
Sleep mode	Modbus, slow
Parity, stop bits	even par, 1 stop
Baud rate	19200
Flow control	off
Transmitter warm-up time	10 ms
Minimum response time	30 ms

11.5.5 How do I switch back to Sommer protocol?

Follow the instructions below to change the data output back to Sommer-protocol:

1. Open the **Connections (F8)** tab and click **New connection**.

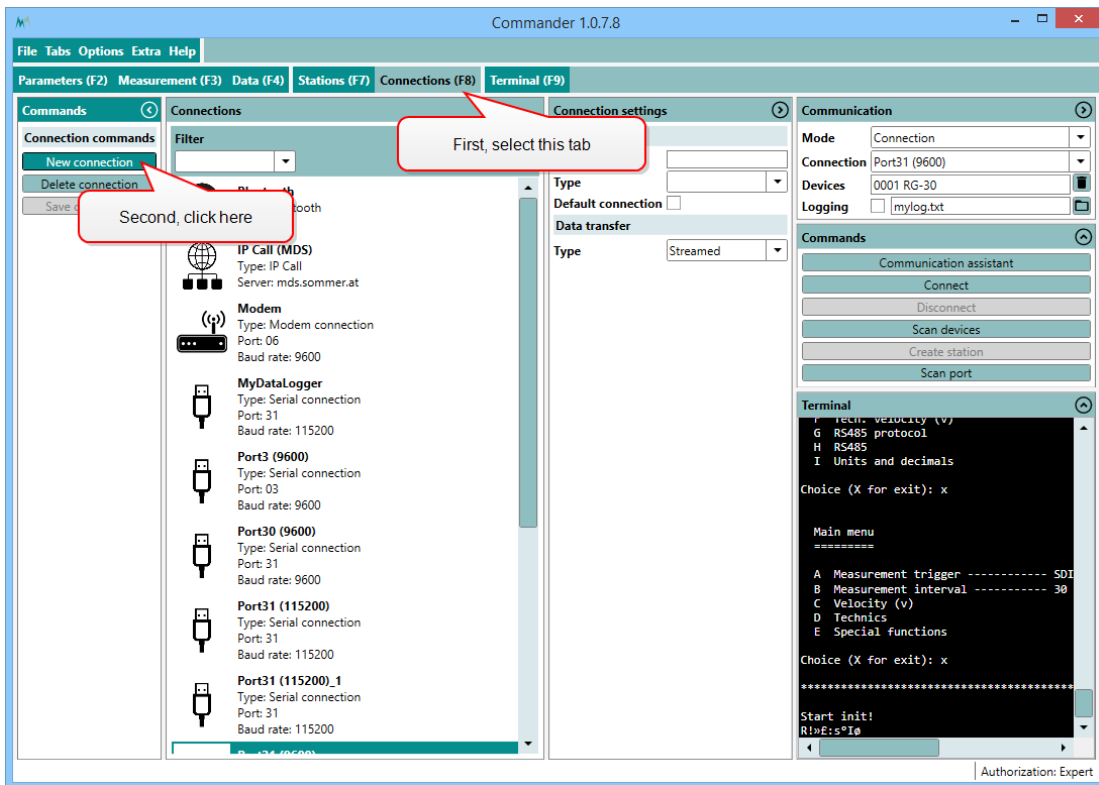

2. Enter the **Name** of the new connection. We recommend to use a meaningful name for later recognition, e.g. Modbus31 (19200) to indicate port 31 and Baud-rate 19200. Select the **Type Serial connection** and choose the **Port** your sensor is connected to, set the **Baud-rate** to **19200** and the **Parity/stop bits** to **Even par., 1 stop bit**.



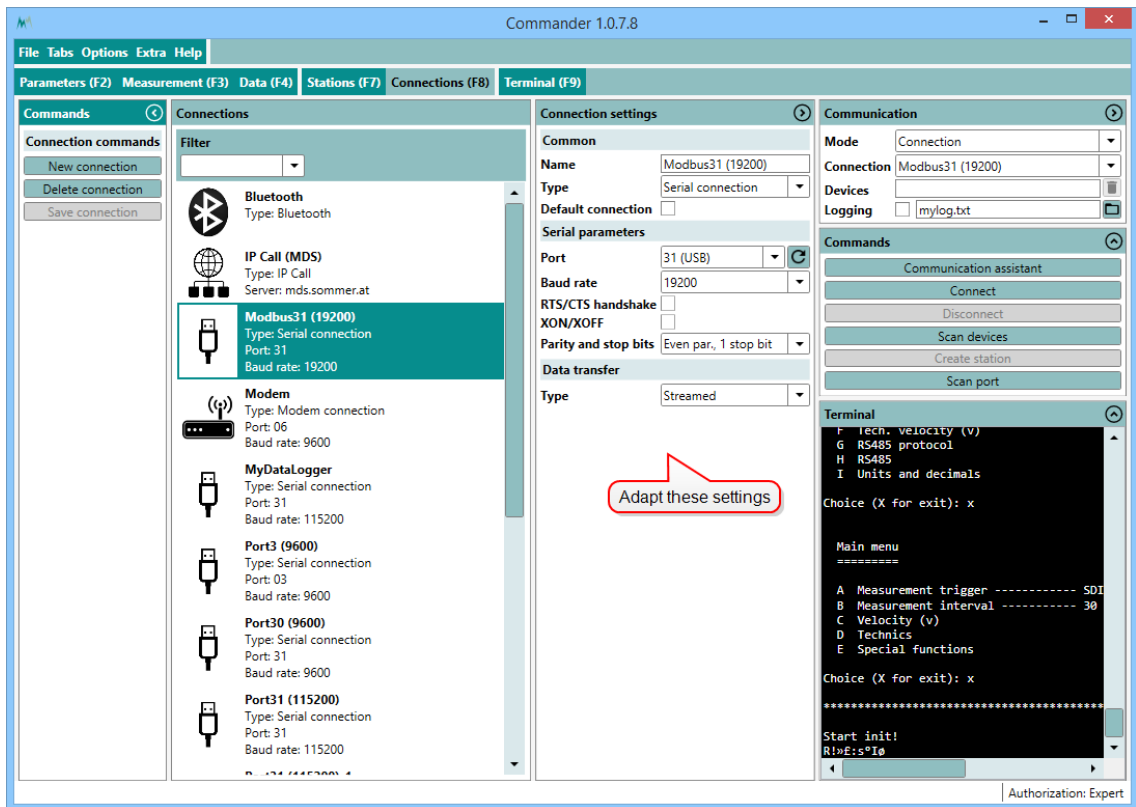

3. Click **Save connection**.
4. In the Communication window select **Mode Connection** and choose the **Connection** you have created. Then click **Connect**.

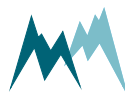

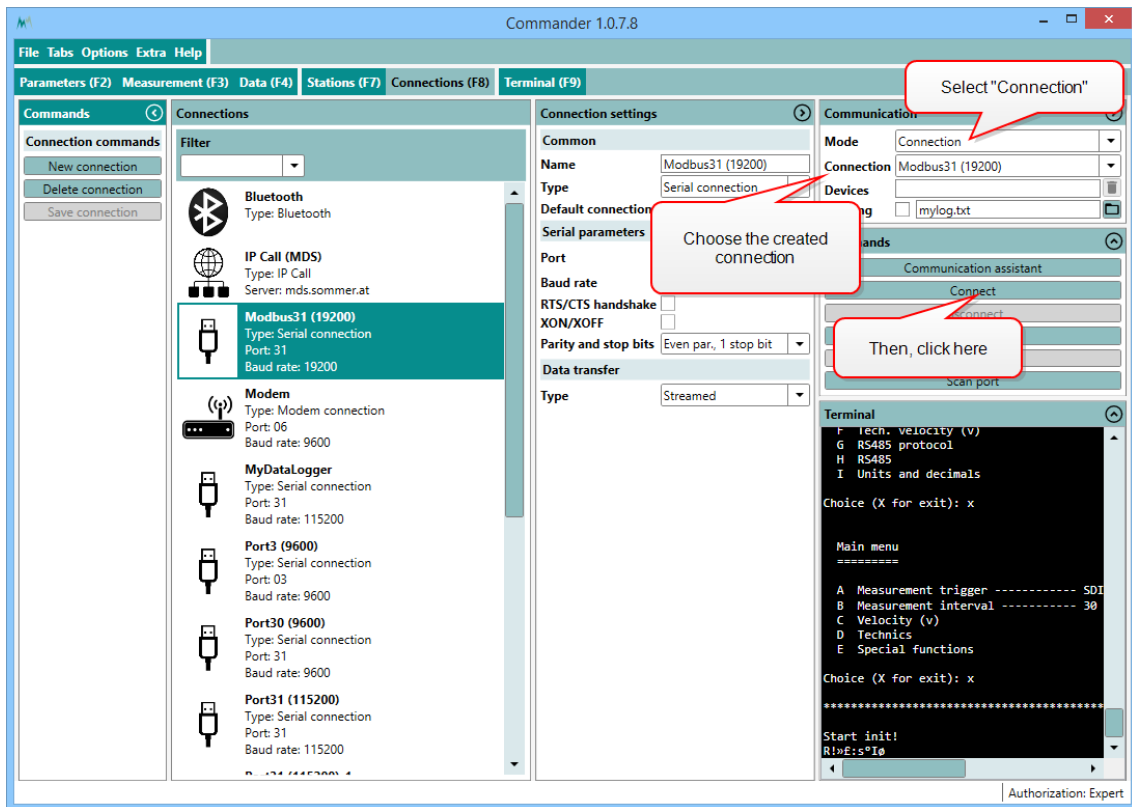

- Download the parameters and save the parameter file as described in [How do I configure it?](#).



TIP Save the parameter file for future use and to document configuration changes!

- Now, two options are available to revert communication back to the Sommer-protocol:
 - If a parameter file is available that has the Sommer-protocol enabled, the file can be loaded by clicking [Open parameter file](#), selecting the respective file and uploading the parameters to the device by clicking [Upload all parameters to device](#).

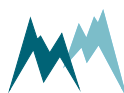

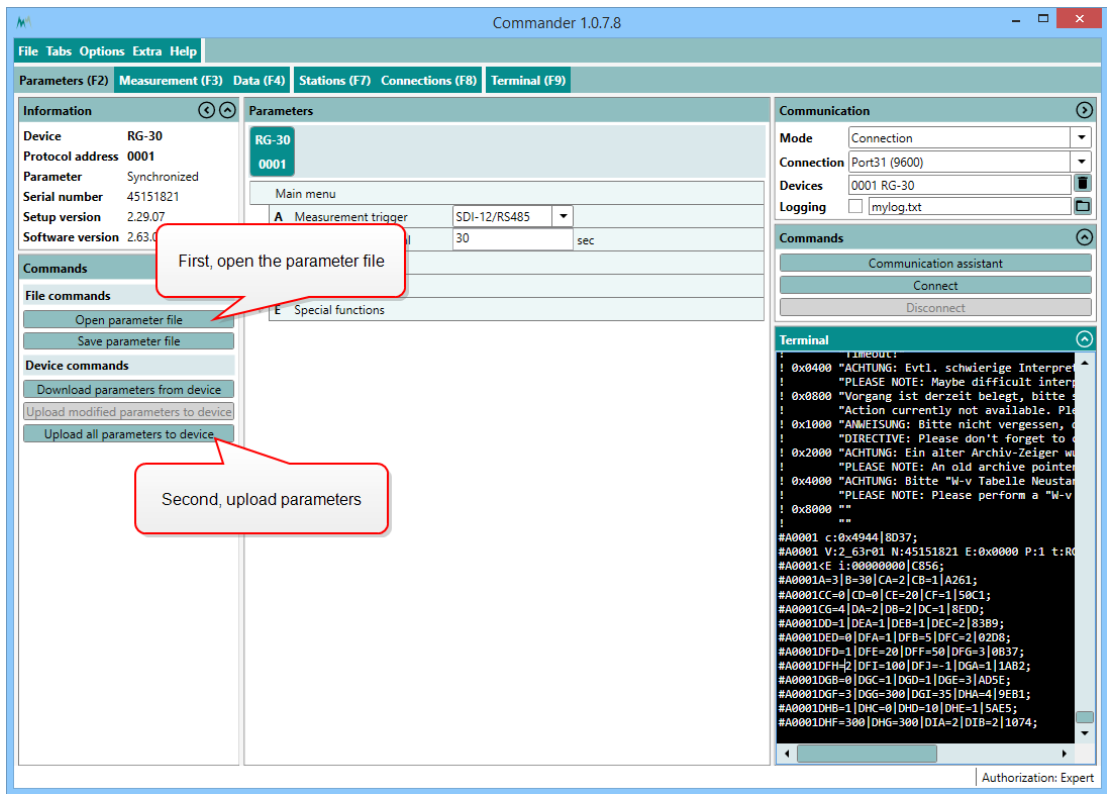

B. If no parameter file is available, the device has to be reset to its default configuration:

1. Click into the **Terminal** window and type ??? to enter the sensor-menu.

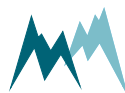
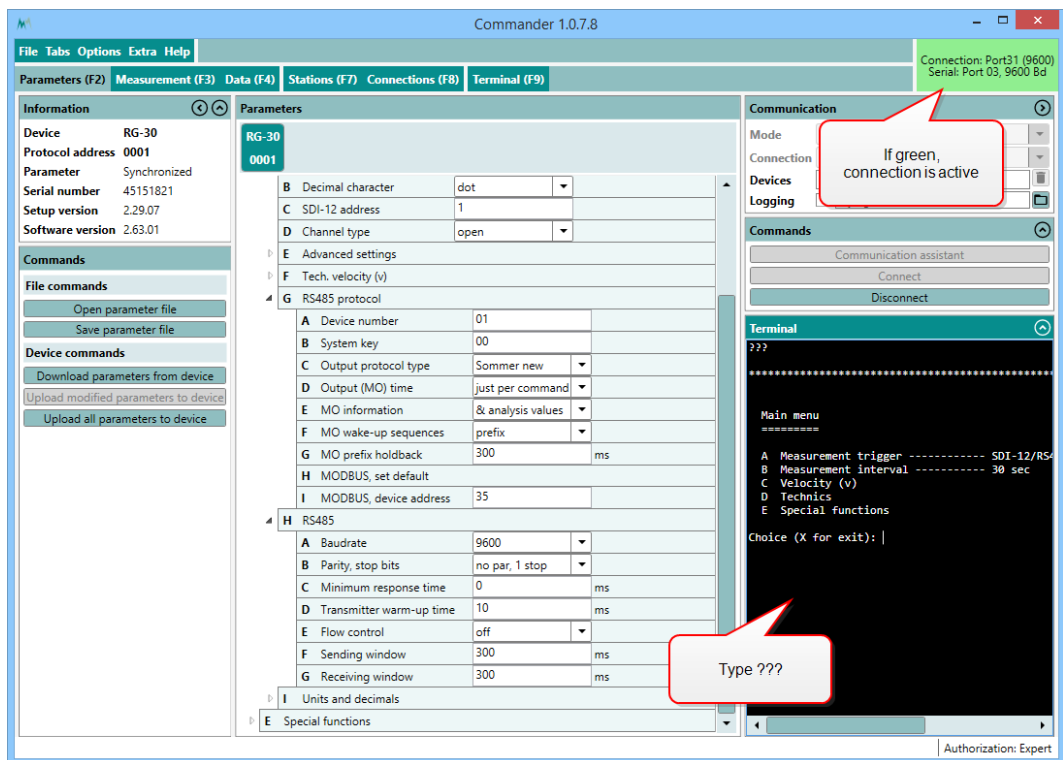

2. Navigate to [Special functions](#) and select [Set factory default...](#)
3. Acknowledge the safety-note.

```
Start up testmode: 0x07

Set factory default
^^^^^^^^^^^^^^^^^^^^

PLEASE NOTE: Please save all parameters before!
PLEASE NOTE: All user settings will be lost!
Are you sure?

(Press "RETURN" to assume)
(Press "Esc" to cancel)

=> Testmode finished!
```

4. Enter `X` until you get back to the main menu. The Sommer-sensor is now restarted and available in its initial configuration. As the connection-parameters have been changed to the default settings, the connection to the sensor is lost. Press [Disconnect](#) for completion.
7. Establish the original connection to the Sommer-sensor as described in [How do I configure it?](#).
8. Download the sensor's parameters in the [Parameters \(F2\)](#) tab, adapt the required parameters, or upload your originally saved parameter file to the USH-9.

11.5.6 Which commands are available?

Read measurement values

Measurement values are read from the registers of function 04 (read input registers, read only):

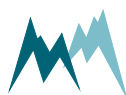

	Register address	Variable	Unit / value	Bytes	Format
Tes value	0	Hardcoded test value	2.7519...	4	float
Main values	2	Level	mm ¹	4	float
	4	Distance	mm ¹		
	6	Temperature	°C/F		
	8	Status	-		
Special values	10	Precipitation	-	4	float
	12	Signal quality	dB		
	14	Std. deviation	mm ¹		
	16	Supply voltage	V		

¹Unit according to submenu .

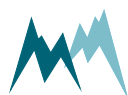

	Register address	Variable	Unit / value	Bytes	Format
Analysis values	18	Signal focus	dB	4	float
	20	Signal strength	dB		
	22	Half-value width	%		
	24	Noise ratio 50	%		
	26	Noise ratio 85	%		
	28	Echo amp.	-		
	30	Var. 1	-		
	32	Var. 2	-		
	34	Var. 3	-		
	36	Dist. max. echo	mm		
	38	Dist. last echo	mm		
	40	Distance 0 C	mm		
	42	Case temperature	°C/F		
	44	Error code	-		
Device info	65533	Device type and configuration	320X	2	unsigned int
	65534	Software version	XYYZZ	2	unsigned int
	65535	Modbus implementation version	10100	2	unsigned int

Table 23: Function 04 Read input registers

Write single registers and read holding registers

Some RS-485 port settings can be written to the registers of function 06 (write single registers) or read from the registers of function 03 (read holding registers):

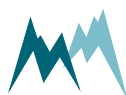

	Register address	Variable	Range	Bytes	Format
Config values	0	Modbus default ¹	0 - 1...read 1...write	2	unsigned int
	1	Modbus device address	1 to 247		
	2	RS-485 baud rate	0...1200 baud 1...2400 baud 2...4800 baud 3...9600 baud 4...19200 baud 5...38400 baud 6...57600 baud 7...115200 baud		
	3	RS-485 parity/ stop bits	0...no parity, 1 stop bit 1...no parity, 2 stop bits 2...even parity, 1 stop bit 3...odd parity, 1 stop bit		

Table 24: Function 06 and Function 03 to read and write configuration values

Report slave ID

The Modbus function 17 (report slave ID, read only) can be used to read basic information of the USH-9. The following example shows the response of function 17 of a RG-30 sensor, which is received in hex-format:



EXAMPLE 23 11 26 53 FF 27 74 20 53 6F 6D 6D 65 72
20 20 52 47 2D 33 30 20 20 20 32 5F 37 31 72 30 31
20 34 35 31 35 31 38 32 31 00 BB D4

¹Writing "1" sets the Modbus default settings.

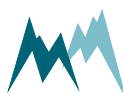

			Example	
	Content	Length (Bytes)	HEX-value	Decimal, ASCII
PDU ¹ response	Slave address	1	23	35
	Function code	1	11	17
	Number of bytes (excl. slave-address, function code, NUL and CRC)	1	26	38
	Slave ID	1	53	"S"
	Run status (0=inactive; FF=active)	1	FF	255
	Modbus implementation version	2	27 74	10100
	Separator	1	20	" "
	Vendor string	7	53 6F 6D 6D 65 72 20	"Sommer "
	Separator	1	20	" "
	Device configuration	7	52 47 2D 33 30 20 20	"RG-30 "
	Separator	1	20	" "
	Software version	7	32 5F 37 31 72 30 31	2_71r01
	Separator	1	20	" "
	Serial number	8	34 35 31 35 31 38 32 31	45151821
	NUL	1	00	
CRC	2	BB D4		

Table 25: Function 17 to report slave ID

¹Protocol Data Unit

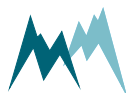

11.5.7 PLC integration

The USH-9 can be integrated into a PLC system as a slave device. It supports the PROFIBUS, PROFINET, EtherCAT and CANopen protocols. This requires an additional serial converter, e.g. Anybus Communicator.

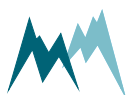

12 Analog output

12.1 What can I do with it?

Measurement values of level, distance, temperature and a status can be returned by two analog 4...20 mA signals. These analog signals can then be used to trigger a certain action, e.g. operate a switch.

12.2 How do I wire it?

The analog outputs of the USH-9 can be connected to a data logger according to the figure below.

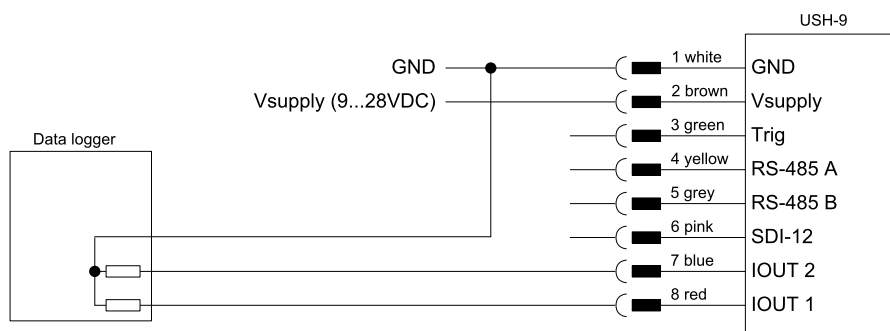

Figure 9 Wiring of analog outputs



NOTE If a data logger is connected to the IOOUT outputs, the resistance of the logger input(s) must not exceed 470 Ω.

12.3 How do I configure it?

The variables and their analog output range are configured in [IOOUT settings](#) as described below:



NOTE

The analog outputs may return currents between 0 and 21 mA. However, the accuracies stated in the specifications are only valid for signals within 4 to 20 mA!

If the measured value falls below or exceeds the 3.9...21 mA range, 3.9 mA and 21 mA, respectively, are returned. An exception are the measurement values 99999998 and 99999997, which return a 3.8-mA and 3.7-mA signal, respectively.

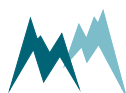



ATTENTION The 4-mA output should correspond to a measurement value at or below the expected minimum! With low current output the accuracy tends to decrease and cross-talk with other analog channels may occur.

12.3.1 Output status

The state of the analog output can be set to the following options:

Option	Description
off (default)	Analog outputs are inactive.
just during TRIG	Analog outputs are only active, if an external signal is present at the TRIG input. The outputs are high as long as the signal at the TRIG input is high.
always on	Analog outputs are permanently active.



NOTE The USH-9 delays analog data acquisition by 200 ms. If **Output status** is set to *just during TRIG*, the analog output must be read with a delay of min. 200 ms after the trigger has been sent. This ensures that the analog measurement has sufficiently stabilized. As the analog measurement itself requires some time, the result should be read with a delay of *measurement duration + min. 1 second*.

12.3.2 IOUT 1

The measured level or distance can be returned as an analog 4...20 mA signal on pin 8 of the MAIN connector. Select level or distance in **IOUT1, function**. The span and offset have to be selected to cover the maximum expected level. See the illustration below for the default configuration.



EXAMPLE

In the default configuration the parameter **IOUT1, 4 mA value** is set to *0* and **IOUT1, 4-20 mA span** to *10'000 mm*, as illustrated below. If the USH-9 is mounted at a lower height, it is recommended to keep this setting.

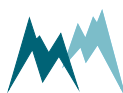

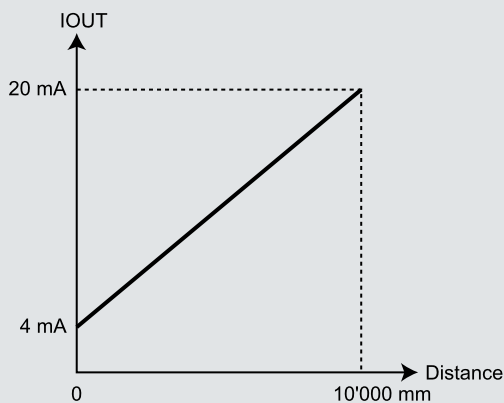

12.3.3 IOU2

The measured air temperature or a status as configured in [Status limits](#) in can be returned as an analog 4...20 mA signal on pin 7 of the MAIN connector.

If the air temperature is selected as output, the span is set to 100 °C and the offset to -40°C as default.

If one of the status options is selected and the conditions specified in [Status limits](#) are satisfied, the output is set to high (20 mA) and otherwise to low (0 mA). The following status options are available:

Option	Description
off (default)	IOU2 is inactive.
value, temperature	The air temperature is returned.
status, level limit	If the level exceeds the limit specified in Level limit , 20 mA is applied, otherwise 0 mA.
status, snow settling	If the USH-9 detects a snow cover 20 mA is applied, otherwise 0 mA. A snow cover is detected if Snow settling, strength drop exceeds the specified limit and Snow settling, maximum level is not reached.
status, snowfall	If the USH-9 detects snowfall 20 mA is applied, otherwise 0 mA. Snowfall is detected if Snowfall, precipitation limit is exceeded and the temperature is below Snowfall, max. temperature .
status, all limits	If any limit mentioned above is violated, 20 mA is applied, otherwise 0 mA.

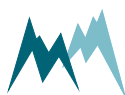

12.3.4 Simulate current output

With this function the analog outputs can be simulated. A user-defined current value between 4 and 20 mA is applied to the analog output pins, which can be read with a connected data logger or multimeter. By pressing Return/Enter again the simulation stops.

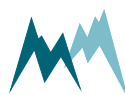

13 Parameter definitions

A	Measurement trigger	81
B	Measurement Interval	81
C	Level and distance	82
D	Technics	84
E	Special functions	100
F	Measurement table	101

A Measurement trigger

Measurements are initiated by one of the options listed in the table below.

The commands to trigger measurements via RS-485 and SDI-12 are described in [Section 11.3.8](#) and [Section 11.4.6](#), respectively.

Measured data are either returned directly after the measurement or can be requested by commands via the RS-485 or SDI-12 interface. The format of the returned data can be configured in the sub-menu [Output protocol \(OP\)](#).

Option	Description
Interval (default)	Measurements are initiated in a specified interval.
TRIG input	Measurements are triggered by the positive edge of a DC-voltage signal applied to the TRIG input (low: 0 ... 0.6 V, high: 2.2 ... 28 V, min. pulse width: 30 ms)
SDI-12/RS-485	Measurements are externally triggered by commands via RS-485 or SDI-12 from ,e.g. a data logger.
all allowed	Measurement is triggered by all options mentioned above.

B Measurement Interval

An internal measurement interval can be set for the USH-9. If selected in menu item [Measurement trigger](#), measurements are performed in the defined interval. However, a measurement is always completed before a new one is initiated.

Unit	sec	seconds
Value range	20...10'800	60 sec (default)

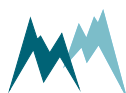

C Level and distance

C-A	Measurement duration	82
C-B	Level/distance test	82
C-C	Adjust level	82
C-D	Distance to zero level	82
C-E	Application	83
C-F	Moving filter, duration	83
C-G	Moving filter, type	84

C-A Measurement duration

The duration of a single measurement. During this time the ultrasonic signal is recorded and the distance to the monitored surface calculated. Generally, a measurement duration of 6 s is recommended.

Unit	sec	seconds
Value range	2...20	6 sec (default)



ATTENTION A longer measurement time increases power consumption but also improves the precision of the results.

C-B Level/distance test

Function to test the level/distance measurement. Initiates a measurement and returns the current distance and level.

C-C Adjust level

Function to adjust the level measurement of the USH-9 to the actual level. It first initiates a measurement and then requests the actual level. Adjusting the level will alter the parameter [Distance to zero level](#).

C-D Distance to zero level

The distance between the sensors lower edge and the ground surface, e.g. lowest point of river bed, ground without snow.

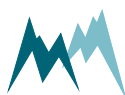

Unit	mm	
Value range	-9'999'999...99'999'999	10'000 (default)

C-E Application

Switch to activate the settings for specific applications as listed in the following table:

Option	Description
snow (default)	Settings for snow applications are active. These settings include precipitation detection and snowfall limits (see Status limits and Advanced settings). Rate of change filtering (RoC, max. without precip. (./h) and RoC, max. at precip. (./h)) is active.
water	Settings for water application are active. Precipitation detection and rate of change filtering (RoC) are deactivated.
others	Settings for water and snow applications are inactive. Used for generic level/distance measurements. A constant rate of change filter (Rate of change, maximum (./h)) is active.

C-F Moving filter, duration

Every level/distance measurement is stored internally in a buffer for filtering. This setting defines the length of the time window of which the data are stored in the buffer. If the buffer is full, the oldest value is replaced by the most recent one.

The figure below illustrates the default moving filter duration of 180 seconds. While a [Measurement Interval](#) of 90 seconds embraces two measurement values, an interval of 45 seconds includes 4 values.

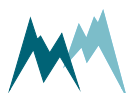
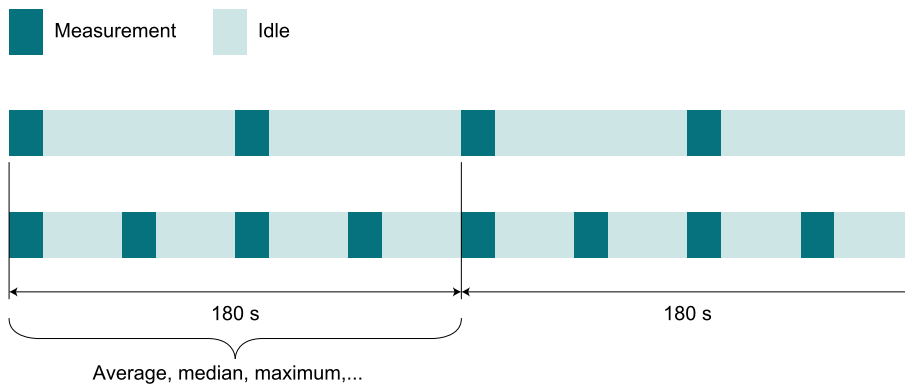

Unit	sec	
Value range	0...99'999'999	180 (default)

C-G Moving filter, type

The level/distance values in the buffer can be filtered by one of the following options:

Option	Description
average	The mean value of all buffered values is calculated.
elim. neg. spikes	To eliminate negative spikes, the mean value is calculated without the 5 lowest buffered values. If the buffer size is smaller than 10, half of the values are eliminated.
maximum	The highest value from the buffer is returned.
median	The median value of the buffered data is returned.
elim. pos. spikes	To eliminate positive spikes, the mean value is calculated without the 5 highest buffered values. If the buffer size is smaller than 10, half of the values are eliminated.
elim. all spike (default)	To eliminate positive and negative spikes, the mean value is calculated without the 5 highest and 5 lowest buffered values. If the buffer size is smaller than 15, two third of the values are eliminated.

D Technics

D-A	Language/Sprache	84
D-B	Decimal character	85
D-C	SDI-12 address	85
D-D	Units and decimals	85
D-E	Temperature	86
D-F	IOUT settings	87
D-G	Status limits	90
D-H	Advanced settings	92
D-I	RS-485 Protocol	95
D-J	RS-485 Port	98

D-A Language/Sprache

The menu language.

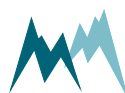

Option	Description
german/deutsch	German language
english/englisch (default)	English language

D-B Decimal character

The character used as decimal separator in the values of the settings and in serial data strings.

Option	Description
comma	-
dot (default)	-

D-C SDI-12 address

The address is a unique identifier of the sensor within a SDI-12 bus system.

Value Range	0...9, a...z, A...Z	0 (default)

D-D Units and decimals

D-D-A	Level, unit	85
D-D-B	Level, decimals	86
D-D-C	Temperature, unit	86
D-D-D	Temperature, decimals	86

D-D-A Level, unit

The following units of the level/distance can be selected:

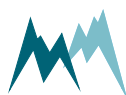

Option	Description
mm (default)	Millimeter
cm	Centimeter
m	Meter
in	Inch
ft	Feet
yd	Yard

D-D-B Level, decimals

The number of decimal places for the measured level/distance.

Value range	0...6	0 (default)
-------------	-------	-------------

D-D-C Temperature, unit

The following units of the air temperature can be selected:

Option	Description
°C (default)	Degrees Celsius
°F	Fahrenheit

D-D-D Temperature, decimals

The number of decimal places for the measured air temperature.

Value range	0...6	2 (default)
-------------	-------	-------------

D-E Temperature

D-E-A	Offset	87
D-E-B	Adjustment	87

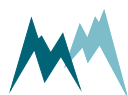

D-E-C Test87

D-E-A Offset

Offset of the USH-9 temperature sensor. An offset might be required if the sensor needs to be matched to an external reference.

Unit	°C	
Value range	-9'999.99...99'999.99	0 (default)

D-E-B Adjustment

Function to adjust the measurement of the USH-9 temperature sensor. Applying this function will update the setting [Offset](#).

D-E-C Test

Function to test the USH-9 temperature sensor.

D-F IOUT settings

D-F-A Output status87
 D-F-B IOUT1, function88
 D-F-C IOUT1, 4-20 mA span88
 D-F-D IOUT1, 4 mA value88
 D-F-E IOUT2, function89
 D-F-F IOUT2, temperature 4-20 mA span89
 D-F-G IOUT2, temperature 4 mA value89
 D-F-H IOUT2, status hold time90
 D-F-I Simulate current output90

D-F-A Output status

The status defines the behavior of the analog outputs.

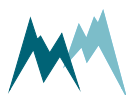

Option	Description
off (default)	Analog outputs are inactive.
just during TRIG	Analog outputs are only active, if an external signal is present at the TRIG input. The outputs are high as long as the signal at the TRIG input is high.
always on	Analog outputs are permanently active.

D-F-B IOUT1, function

Defines the variable returned by IOUT1. The following options are available:

Option	Description
distance (default)	The distance between sensor and snow surface is returned.
level	The level is returned (distance between ground and snow surface)

D-F-C IOUT1, 4-20 mA span

Defines the output range of the 4-20 mA signal of IOUT1. The span should cover the expected range of the level or distance, respectively.



EXAMPLE

Minimum level: 0 cm

Maximum expected level: 400 cm

This gives an offset of 0 cm and a level span of 400 cm. To interpret the output more easily select a span value of 480 cm; thus, a current of 1 mA corresponds to a level of 30 cm.

Unit	Unit of level	
Value range	-9'999'999...99'999'999	10'000 (default)

D-F-D IOUT1, 4 mA value

Defines the minimum level/distance that corresponds to the 4 mA current output. For snow depth this value is usually zero.



Unit	Unit of level	
Value range	-9'999'999...99'999'999	0 (default)

D-F-E IOOUT2, function

Defines the variable returned by IOOUT2. The following options are available:

Option	Description
off (default)	IOOUT2 is inactive.
value, temperature	The air temperature is returned.
status, level limit	If the level exceeds the limit specified in Level limit , 20 mA is applied, otherwise 0 mA.
status, snow settling	If the USH-9 detects a snow cover 20 mA is applied, otherwise 0 mA. A snow cover is detected if Snow settling, strength drop exceeds the specified limit and Snow settling, maximum level is not reached.
status, snowfall	If the USH-9 detects snowfall 20 mA is applied, otherwise 0 mA. Snowfall is detected if Snowfall, precipitation limit is exceeded and the temperature is below Snowfall, max. temperature .
status, all limits	If any limit mentioned above is violated, 20 mA is applied, otherwise 0 mA.

D-F-F IOOUT2, temperature 4-20 mA span

Defines the output range of the 4-20 mA signal of IOOUT2 . The span should cover the air temperature range expected at the measurement site.

Unit	Unit of temperature	
Value range	-9'999'999...99'999'999	100 (default)

D-F-G IOOUT2, temperature 4 mA value

Defines the minimum air temperature that corresponds to the 4 mA current output.

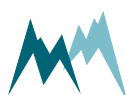

Unit	Unit of temperature	
Value range	-9'999'999...99'999'999	-40 (default)

D-F-H IOUT2, status hold time

If a limit defined in [Status limits](#) is reached, the status of IOUT2 is set to high and 20 mA is applied to the output. This status is maintained until the specified hold time elapses. Setting this parameter suppresses a flickering signal if the monitored variable fluctuates around the limit value.

Unit	min	
Value range	0...360	30 (default)

D-F-I Simulate current output

With this function the analog outputs can be simulated. Upon submission of a current value between 4 and 20 mA the corresponding values of the selected variable are displayed. The selected current is also applied to the analog outputs and can be read with a connected data logger or multimeter. By pressing Return/Enter again the simulation stops.



NOTE

If [Output status](#) is deactivated, no current output can be simulated.

If [Output status](#) is set to [just during TRIG](#), the trigger must be set prior to simulation. Additionally, the trigger must be reset before each simulation.

D-G Status limits

D-G-A	Level limit	90
D-G-B	Snow settling, strength drop	91
D-G-C	Snow settling, maximum level	91
D-G-D	Snowfall, precipitation limit	91
D-G-E	Snowfall, max. temperature	92

D-G-A Level limit

The level above which the status is set to high. This limit is used to report significant levels or snow depths.

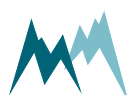

Unit	mm	
Value range	0...99'999'999	0 (default)

D-G-B Snow settling, strength drop

Only available if **Application** is set to *snow*. Generally used to detect snow settling, e.g. for monitoring of road conditions. If the signal strength drops by the specified value, snow starts to build up on a previously snow-free surface.

Unit	dB	
Value range	0...50	0 (default)

D-G-C Snow settling, maximum level

Only available if **Application** is set to *snow*. Generally used to detect snow settling, e.g. for monitoring of road conditions.

When snow starts to accumulate on a previously snow-free surface, and **Snow settling, strength drop** falls below its limit, the status “snow settling” is set to high. Once the maximum level is reached, the status is set to low again.

Unit	mm	
Value range	0...99'999'999	50 (default)

D-G-D Snowfall, precipitation limit

Only available if **Application** is set to *snow*; used to report snowfall. The USH-9 returns precipitation as dimensionless value that represents both, precipitation type and intensity. To identify precipitation as snow and to trigger the status “snowfall”, the value must exceed the specified limit, and the air temperature must be lower than **Snowfall, max. temperature**..

Unit	-	
Value range	0...1'000	0 (default)

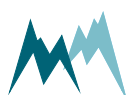

D-G-E Snowfall, max. temperature

Only available if [Application](#) is set to *snow*; used to report snowfall. The air temperature below which precipitation is expected to fall as snow.

Unit	Unit of temperature	
Value range	-99'999.99...99'999.99	2.0 (default)

D-H Advanced settings

D-H-A	Optimisation	92
D-H-B	Max. measurement distance	92
D-H-C	View spectral distribution	93
D-H-D	Maximum standard deviation	93
D-H-E	Rate of change, maximum (./h)	93
D-H-F	RoC, max. without precip. (./h)	93
D-H-G	RoC, max. at precip. (./h)	94
D-H-H	Precipitation, filter duration	94
D-H-I	Reset behavior	94
D-H-J	Sleep mode	95
D-H-K	Sommer ID	95

D-H-A Optimisation

Only available if [Application](#) is set to *water* or *others*. Adapts the settings of the level/distance analysis to the conditions of the sensors environment.

Option	Description
indoor (default)	The USH-9 does not apply confirmation shots to determine the level/distance.
outdoor	The USH-9 applies confirmation shots to determine the level/distance.

D-H-B Max. measurement distance

Maximum expected distance between the sensor and the target surface. A shorter distance increases precision. This may be required if the zero level (specified in [Distance to zero level](#)) has a datum that is outside the measurement range. The minimum value is 1000 mm.

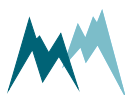

Unit	mm	
Value range	1'000...99'999'999	10'000 (default)

D-H-C View spectral distribution

With this command the ultrasonic sensor is set into spectral mode. After 30 minutes the spectral mode is switched off automatically.

With the Commander software the spectra can be recorded, visualized and stored for expert analysis of the ultrasonic signal, e.g. additional reflections.

D-H-D Maximum standard deviation

At the beginning of each measurement the USH-9 fires an impulse to detect the approximate position of the snow surface. Subsequent impulses then determine the exact snow depth. This setting specifies the maximum acceptable standard deviation of a complete measurement.

Unit	mm	
Value range	0...99'999'999	70 (default)

D-H-E Rate of change, maximum (./h)

Only applicable if **Application** is set to *others*. Maximum permissible rate at which the level is allowed to change.

Unit	mm/h	
Value range	0...99'999'999	30 (default)

D-H-F RoC, max. without precip. (./h)

Only applicable if **Application** is set to *snow*. Maximum permissible rate at which the level is allowed to change when there is no snowfall.

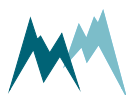

Unit	mm/h	
Value range	0...99'999'999	300 (default)

D-H-G RoC, max. at precip. (./h)

Only applicable if **Application** is set to *snow*. Maximum permissible rate at which the level is allowed to change during snowfall.

Unit	mm/h	
Value range	0...99'999'999	300 (default)

D-H-H Precipitation, filter duration

Only available if **Application** is active. As the signal reflected by precipitation is very noisy, the USH-9 filters the precipitation value by a moving average with the specified filter duration.

Unit	sec	
Value range	0...99'999'999	360 (default)

D-H-I Reset behavior

The USH-9 keeps certain sensor data in its memory, e.g. the measured data for calculation of the moving average. This setting defines whether the acquired sensor data are deleted upon a sensor reset or not.

Option	Description
hard reset	A reset deletes all acquired and stored sensor data.
soft reset (default)	All acquired and stored sensor data are kept for measurements and calculations.



NOTE During the installation a hard reset is recommended. After finishing the installation a soft reset should be selected. This shortens start-up time.



D-H-J Sleep mode

Defines the behavior of the USH-9 between two measurements, provided the measurement interval is longer than the time of the measurement itself. The following options are available:

Option	Description
MODBUS, fast	For MODBUS applications. The USH-9 stays in normal mode. This option permits high data transmission rates, but increases power consumption.
MODBUS, slow	For MODBUS applications. The USH-9 goes into idle mode and can be woken up by a command via the RS-485 interface with a low baud rate. This option reduces power consumption at lower data transmission rates.
Standard (default)	The USH-9 goes into sleep mode and can be woken up by a command via the RS-485 interface only with a time delay. Option with the lowest power consumption.

D-H-K Sommer ID

The Sommer ID is used to define stations within the Commander software. The ID is preset in the device and corresponds to its serial number. SOMMER suggests not to change the ID, except if a USH-9 device is replaced. In such a case it can be practical to change the ID of the new device to the ID of the replaced device to guarantee data consistency.

D-I RS-485 Protocol

D-I-A	Device number	95
D-I-B	System key	96
D-I-C	Output protocol (OP)	96
D-I-D	OP, measurement output	96
D-I-E	OP, information	97
D-I-F	OP, wake-up sequence	97
D-I-G	OP, prefix holdback	97
D-I-H	MODBUS, set default	98
D-I-I	MODBUS, device address	98

D-I-A Device number

The device number is used for the unique identification of the device in a bus system.

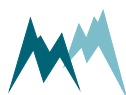

Value range

0...98

0 (default)

D-I-B System key

The system key defines the bus system of the device. Thus, different conceptual bus systems can be separated. Interfering bus systems occur if the remote radio coverage of two measurement systems overlap. In general, the system key should be set to 00.

Value range

0...99

0 (default)

D-I-C Output protocol (OP)

The type of the serial output protocol. The following options are available:

Option	Description
Sommer (default)	Sommer protocol; data values are returned with an index starting at 1
Standard	Standard protocol; data values are returned without an index
MODBUS	Modbus protocol



NOTE For MODBUS applications run **MODBUS, set default** to get the appropriate communication settings.

D-I-D OP, measurement output

Specifies the timing of the serial data output.

Option	Description
just per command	The output is only requested by commands via the RS-485 or SDI-12 interface.
after measurement (default)	The serial data output is performed automatically right after each measurement.
pos. TRIG slope	The output is triggered by a positive edge of a control signal applied to the trigger input.

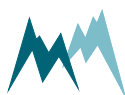

D-I-E OP, information

The main measurement values are always included in the data output string. Additionally, special and analysis values can be included.

Option	Description
main values	Only the main values are returned.
& special values (default)	Main values and special values are returned.
& analysis values	Main, special and analysis values are returned.

D-I-F OP, wake-up sequence

Serial data can be transmitted to a recording device automatically without a request. However, many devices demand a wake-up sequence before they can receive and process data. The USH-9 has the option to send a sync sequence and a prefix before data are transmitted (see [Waking-up a connected data logger](#)). The following options are available:

Option	Description
off	No wake-up sequence
sync	The sync sequence UU~?~? is sent before the output string.
prefix (default)	A blank with a time delay is sent before the output string.
prefix & sync	A blank with a time delay and the sync sequence UU~?~? is sent before the output string.

D-I-G OP, prefix holdback

The hold-back time defines the time delay between the prefix and the data string.

Unit	ms	Milliseconds
Value range	0...5'000	300 (default)

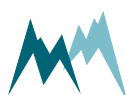

D-I-H MODBUS, set default

Only available in terminal mode. The Modbus protocol demands a defined setting, including multiple parameters. This command sets all these parameters automatically (see [Modbus](#)).

D-I-I MODBUS, device address

Unique device address for the Modbus protocol.

Value range	1...247	35 (default)
-------------	---------	--------------

D-J RS-485 Port

D-J-A	Baud rate	98
D-J-B	Parity, stop bits	98
D-J-C	Minimum response time	99
D-J-D	Transmitter warm-up time	99
D-J-E	Flow control	99
D-J-F	Sending window	100
D-J-G	Receiving window	100

D-J-A Baud rate

The following transmission rates in bps (baud) can be selected:

1'200
2'400
4'800
9'600 (default)
19'200
38'400
57'600
115'200

D-J-B Parity, stop bits

The following combinations of parity and stop bits can be selected:

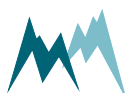

Option	Description
no par, 1 stop (default)	No parity and 1 stop bit
no par, 2 stop	No parity and 2 stop bits
even par, 1 stop	Even parity and 1 stop bit
odd par, 1 stop	Odd parity and 1 stop bit

D-J-C Minimum response time

Setting of this parameter avoids interference of communication at the RS-485 interface. For this purpose the response to a command is delayed by the selected time. Additionally, the response is kept compact.

Unit	ms	Milliseconds
Value range	0...2'000	10 (default)

D-J-D Transmitter warm-up time

The transmitter warm-up time defines the time before data is sent.

Unit	ms	Milliseconds
Value range	0...2'000	10 (default)

D-J-E Flow control

The XOFF-XON flow control can be activated with this setting.

Option	Description
Off (default)	no flow control
XOFF-XON blocking	XOFF-XON flow control, especially adapted for half-duplex systems

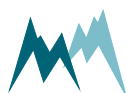



ATTENTION To use spectrum mode ([View spectral distribution](#)) set [Flow control](#) to *XOFF-XON blocking*. This enables a return to normal mode at any time.

D-J-F Sending window

If XON-XOFF flow control is activated data are transmitted in blocks with the defined length.

Unit	ms	Milliseconds
Value range	200...5'000	300 (default)

D-J-G Receiving window

If XON-XOFF flow control is activated transmission of blocks is delayed by the specified time.

E Special functions

E-A	Device status	100
E-B	View setup	100
E-C	Continuous meas. mode (temp).	100
E-D	Set factory default	101
E-E	Temp. load factory default	101
E-F	Relaunch program	101

E-A Device status

Displays information about the sensor and the software version.

E-B View setup

All parameters of the USH-9 are listed in the terminal window.

E-C Continuous meas. mode (temp).

Inactive in the Commander menu. This feature can be triggered under the [Measurement \(F3\)](#) tab with the command [Start polling measurements](#). When active, measurements are performed continuously, ignoring the specified measurement interval.

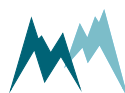

E-D Set factory default

All parameters are reset to factory defaults. Only available in terminal-mode.

E-E Temp. load factory default

Loads factory default values temporarily. Only available in terminal mode.

E-F Relaunch program

The device is restarted. Powering the sensor off and on again is equivalent.

F Measurement table

Lists all measured variables with their units (see [Serial communication](#)).

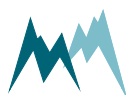

Appendix A Device Errors

By configuring the USH-9 to return analysis values any error of the device can be recorded (see also [Which data do I get?](#)).

The error code is displayed as a decimal number of which the value left of the decimal point refers to fatal errors and the value right of the decimal point to minor errors. By converting these two numbers to their hex-values the errors as listed in the following tables can be identified.



NOTE If multiple errors occur, they are added and the summed error code is returned. The error code can be reset with the function [Device status](#).

Error code	Name	Description
0x00000004	SYSTEM_MAIN_BAD_VSCHUSS_ERROR	Supply voltage is out of bounds.
0x00000008	SYSTEM_MAIN_A6V0TO_LOW_ERROR	6V power supply for analog outputs and RS-485 interface is out of bounds.
0x00000010	SYSTEM_PRIMADC_NOXREF_ERROR	Power supply of AD-converter that reads the Pt1000 output is out of bounds.
0x00000020	SYSTEM_PRIMADC_BAD_SW_ERROR	Obsolete
0x00000040	SYSTEM_PRIMADC_AD7798_ERROR	Error-bit of AD-converter is set.
0x00000080	SYSTEM_PRIMADC_TIMEOUT_ERROR	AD-converter receives no results.
0x00000100	SYSTEM_PRIMADC_NOTCALIB_ERROR	Pt1000 is not or badly calibrated.
0x00000200	SYSTEM_PRIMADC_OUT_OF_BOUNDS_ERROR	Current across Pt1000 and shunt resistor is too low.



Error code	Name	Description
0x00000400	SYSTEM_SCAN_ERROR	Measurement has been canceled.
0x00000800	SYSTEM_SCAN_BLOCKED_NEARFIELD	The target surface or another object is within the near field of the USH-9. Subsequent measurement may be invalid!
0x00001000	SYSTEM_SCAN_MIXEDMIRRORCONDIDITIONS	May only occur during indoor-use. Subsequent ultrasonic shots have identified different peaks. USH-9 returns <i>Hold</i> value.

Table 1: Fatal device errors

Error code	Name	Description
0x01	SYSTEM_MAIN_AVEXT_ERROR	Voltage of external power supply is not measured correctly.
0x02	SYSTEM_MAIN_A6V0_ERROR	Voltage of 6V power supply is too high.
0x04	SYSTEM_MAIN_TEMP_ERROR	Internal temperature sensor returns invalid data.
0x08	SYSTEM_NO_TARGET_CLEARANCE	May only occur during outdoor-use. Spread of distance acquired by confirmation-shots is too large.
0x10	SYSTEM_DIFFERENT_MIRRORING	May only occur during indoor-use. If three ultrasonic shots have been fired, and shots one and three returned the same result instead of shots one and two.
0x40	SYSTEM_MAIN_REBOOT_ERROR	Repeated re-boot due to insufficient power supply or manual restarts.

Table 2: Minor device errors

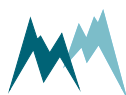

Glossary

M

Modbus

A serial communications protocol for connecting industrial electronic devices.

R

RS-485

A standard defining the signal transmission in serial communication systems.

S

SDI-12

Asynchronous serial communications protocol for intelligent sensors (Serial Digital Interface at 1200 baud)

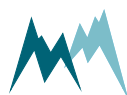

Index

M

Modbus 11, 14, 35, 37, 61-62, 73, 96, 98

R

RS-485 11, 14, 16, 20, 33, 36, 44-45, 47, 54,
61-62, 73, 81, 95-96, 98-99, 102

S

SDI-12 14, 16, 20, 36, 45-46, 56-57, 63, 81,
85, 96

