

INSTRUCTION MANUAL

Radiation Shield with
Temperature Sensor

MT-052-A
MT-052-T

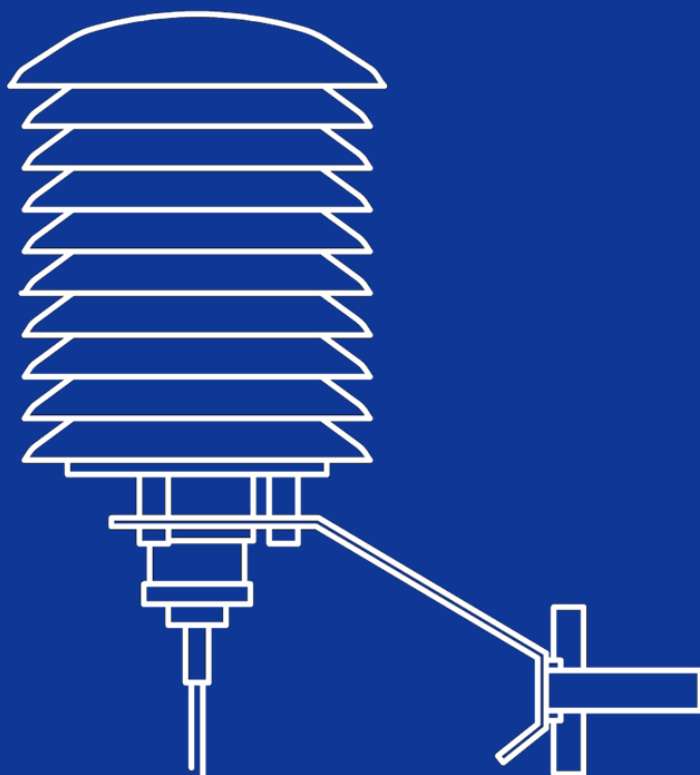

EKO

1. Index

1. Index	1
2. Important User Information	2
2-1. Contact Information	2
2-2. Warranty and Liability	2
2-3. About Instruction Manual	3
2-4. Environment	3
3. Introduction	4
3-1. Main Functions	4
3-2. Package Contents	4
4. Getting Started	5
4-1. Parts Name and Descriptions	5
4-2. Installation	6
4-3. Wiring the Temperature Sensor	8
5. Maintenance & Troubleshooting	10
5-1. Maintenance	10
5-2. Troubleshooting	10
6. Specification	11
6-1. Specification	11
6-2. Dimensions	12
6-3. Accessories List	14
APPENDIX	15
A-1. Wind Speed & Sun Elevation Effects	15
A-2. Conversion Table for Pt100 Temp. Sensor	16

2. Important User Information

Thank you for using EKO Products

Make sure to read this instruction manual thoroughly and to understand the contents before starting to operate the instrument. Keep this manual at safe and handy place for whenever it is needed.

For any questions, please contact us at one of the EKO offices given below:

2-1. Contact Information

EKO INSTRUMENTS CO., LTD.

Asia, Oceania Region

www.eko.co.jp	EKO INSTRUMENTS Co., Ltd.	Tel: +81 (3) 3469-6711
info@eko.co.jp	1-21-8 Hatagaya, Shibuya-ku	Fax: +81 (3) 3469-6719
	Tokyo, 151-0072 Japan	

Europe, Middle East, Africa, South America Region

www.eko-eu.com	EKO INSTRUMENTS Europe B.V.	Tel: +31 (0)70 3050117
info@eko-eu.com	Lulofsstraat 55, Unit 32,	Fax: +31 (0)70 3840607
	2521 AL, Den Haag, The Netherlands	

North America Region

www.eko-usa.com	EKO INSTRUMENTS USA Inc.	Tel: +1 408-977-7751
info@eko-usa.com	95 South Market Street, Suite 300	Fax: +1 408-977-7741
	San Jose, CA 95113 USA	

2-2. Warranty and Liability

For warranty terms and conditions, contact EKO or your distributor for further details.

EKO guarantees that the product delivered to customer has been verified, checked and tested to ensure that the product meets the appropriate specifications. The product warranty is valid only if the product has been installed and used according to the directives provided in this instruction manual.

In case of any manufacturing defect, the product will be repaired or replaced under warranty. However, the warranty does not apply if:

- Any modification or repair was done by any person or organization other than EKO service personnel.
- The damage or defect is caused by not respecting the instructions of use as given on the product brochure or the instruction manual.

2-3. About Instruction Manual

Copy Rights Reserved by EKO INSTRUMENTS CO., LTD. Making copies of whole or parts of this document without permission from EKO is prohibited.

This manual was issued: 2016/12/05
Version Number: 5

2-4. Environment

1. WEEE Directive 2002/96/EC (Waste Electrical and Electronic Equipment)

This product is not subjected to WEEE Directive 2002/96/EC however it should not be mixed with general household waste. For proper treatment, recovery and recycling, please take this product(s) to designated collection points.

Disposing of this product correctly will help save valuable resources and prevent any potential negative effects on human health and the environment, which could otherwise arise from inappropriate waste handling.

2. RoHS Directive 2002/95/EC

EKO Instruments has completed a comprehensive evaluation of its product range to ensure compliance with RoHS Directive 2002/95/EC regarding maximum concentration values for substances. As a result all products are manufactured using raw materials that do not contain any of the restricted substances referred to in the RoHS Directive 2002/95/EC at concentration levels in excess of those permitted under the RoHS Directive 2002/95/EC, or up to levels allowed in excess of these concentrations by the Annex to the RoHS Directive 2002/95/EC.

3. Introduction

MT-052-A Radiation Shield is integrated with MT-010 Temperature Sensor, and MT-052-T Radiation Shield is integrated with MT-010-T temperature sensor. They are designed to measure air temperature under all environmental conditions. The temperature sensor MT-010 is a 4-wirePt100-Class A RTD for accurate temperature measurement. MT-010-T is a T-type thermocouple with copper-constantan. It consists of 10 plastic plates and a metal mounting arm with clamp to mount to any pole.

The passive shield is shaped to allow natural air convection around the sensor while it is minimizing direct exposure to sunlight from all directions, so the air temperature inside the shield is a good representation of the outside air. The shield also provides protection from rain.

A variety of cable lengths is available to encompass most application requirements and simplify wiring sensors.

3-1. Main Functions

1. Outstanding Durability

The radiation shield is designed with a highly reflective white surface to reflect the sun's direct radiation.

2. Natural Ventilation

The multi-plate design allows for natural airflow and prevents internal temperature increase by the solar heat.

3. Accurate Measurement

To accurately measure the outdoor air temperature, an outdoor temperature sensor must be insulated from the direct and indirect effects of the sun and allow sufficient airflow directly to the temperature sensor. For accurate temperature measurements, the MT-052-A combines all of these aspects.

3-2. Package Contents

Check the package contents first; if any missing item or damage is noticed, please contact EKO immediately.

Table 3. Package Contents

Standard Items	Qty.	Remarks
Radiation Shield	1	
Temperature Sensor	1	MT-010 or MT-010-T, Standard Cable Length: 10m
Inspection Report	1	
Instruction Manual	1	

4. Getting Started

4-1. Parts Name and Descriptions

Each part name and its main functions are described below.

1. Radiation Shield



Figure 4-1. Radiation Shield

The radiation shield has the function of a compact instrument shelter; it protects the temperature sensor from direct exposure to solar radiation and rain.

It is made of 10 plastic plates with material of high durability, specially designed to create natural ventilation for actual temperature measurements without the heating effect due to solar exposure.

2. Temperature Sensor



Figure 4-2. Temperature Sensor

1) MT-010

A Platinum resistor temperature sensor (Pt100 Ω) is integrated inside a metal sensor probe with 4-wire cable. See Appendix [A-2. Resistance Temperature Sensor (Pt100 A Class) Conversion Table] for the temperature conversion. This platinum temperature sensor is called "Pt100" since the resistance at zero (0) °C is 100 Ω .

2) MT-010-T

T-type thermocouple with copper-constantan is integrated inside a metal sensor probe. To prevent degradation by humidity, outer coating is made of stainless steel.

4-2. Installation

1. Assembling Temperature Sensor and Radiation Shield

- 1) Remove the protecting cap which is attached to the probe by pulling the cap in upwards direction as shown below on Figure 4-3.

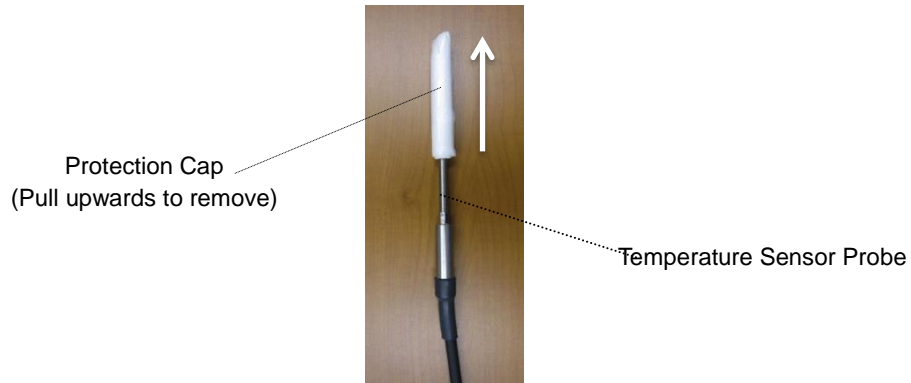

Figure 4-3. Remove Protection Cap

- 2) A cable conduit and clamp is attached to the bottom of the radiation shield as shown in the Figure 4-4.

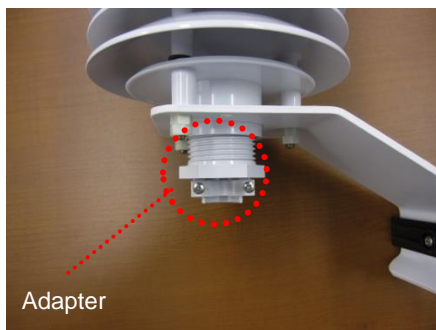

Figure 4-4(a). Cable conduit

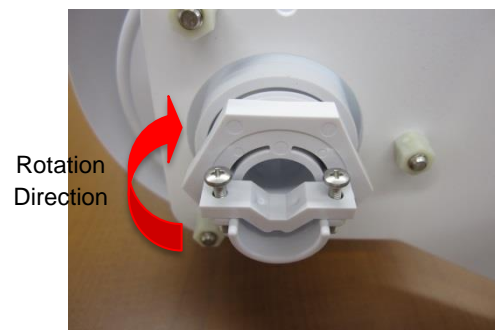

Figure 4-4(b). Adapter Part Enlarged Image

- 3) Put the probe through the cable conduit and tighten the clamp by turning the adapter clockwise until it is securely fixed (2 screws (M2.6 x 15) (Figure 4-5). Make sure that the clamp is holding the metal part of the temperature sensor probe instead of the grey rubber sleeve (Figure 4-6).



Figure 4-5. Insert Temperature Sensor



Figure 4-6. Enlarged Image of Inserted Temperature Sensor

2. Mounting the Radiation Shield

➤ Mounting on a pole

- 1) Free the band attached to the Radiation Shield (Figure 4-7)
- 2) Mount the Radiation Shield by placing the black part of the mounting to the pole ($\phi 40$ to 60mm) to be attached, then fasten the band securely by tightening the screw. (Figure 4-8).



Figure 4-7. Before Fastening Band



Figure 4-8. Mounted on a Pole

➤ Mounting on a wall

- 1) Remove the attached mounting band by loosening the screw attached from the back of the Radiation Shield. (Figure 4-9 and Figure 4-10).
- 2) Mount the Radiation Shield on a wall using screws or bolts and nuts. (Figure 4-11)

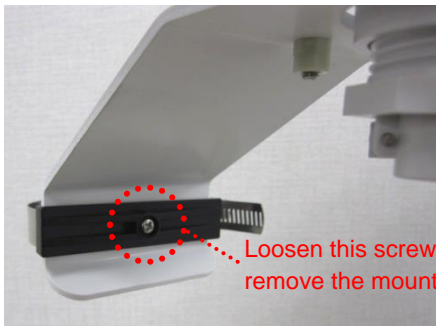

Figure 4-9. Back side of the Mounting Part



Figure 4-10. Without the Mounting Band



Figure 4-11. Fixing with Screws

4-3. Wiring the Temperature Sensor

1. MT-052-A: Wiring

1) Wiring

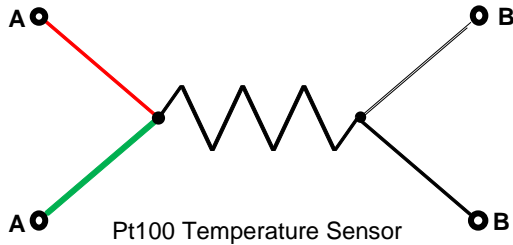

Figure 4-12. Circuit Diagram of the PT100 Temperature Sensor

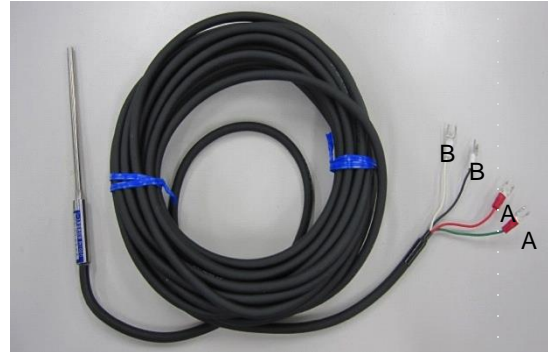

Figure 4-13. Wiring Colors

The 4-Wire Pt100 Temperature Sensor has 2 A and 2 B terminals. With a 4-wire connection, more precise temperature measurements can be performed when the current and voltage terminals are connected separately.

For the 4-wire connection; connect red wire (A) and white wire (B) for current measurement, green wire (A) and black wire (B) for voltage measurement, to each A and B terminal block on the measuring device respectively. (See below [Connection Examples])

NOTE: In case of 3-wire connection, use red wire (A) and white wire (B) for current measurement, and use only the black wire (B) for voltage measurement (Do not use green wire (A)).

2) Connection Examples

➤ 3-wire Connection

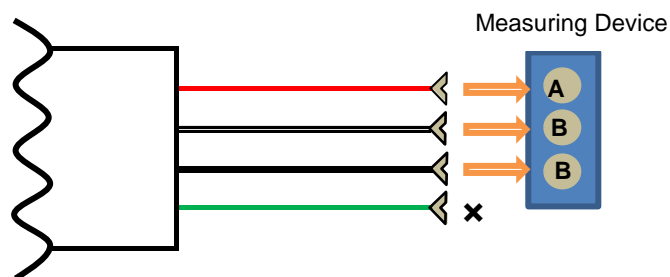

Figure 4-14. 3-wire Connection

NOTE: The extra wire which is not used in the 3-wire connection should be wrapped around with insulated tape or cut at appropriate length so that it will not contact other terminals.

➤ 4-wire Connection

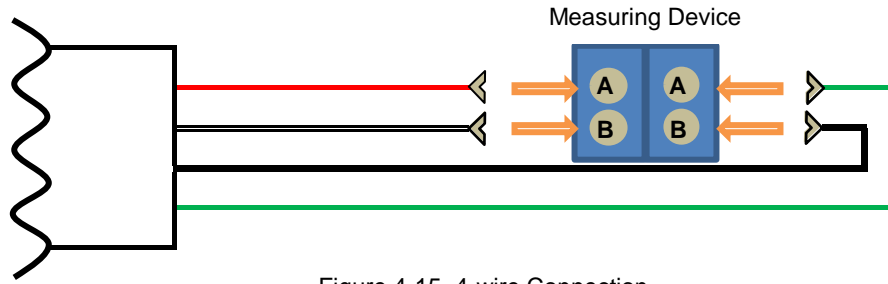

Figure 4-15. 4-wire Connection

NOTE: The connections may differ depending on the measurement device used. Follow the instructions provided by the manufacturer.

2. MT-052-T: Wiring

1) Wiring

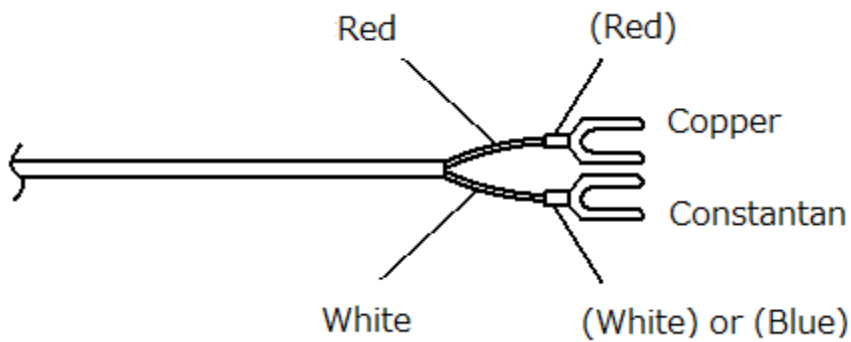

Figure 4-16. MT-052-T Wiring

2) Connection Example

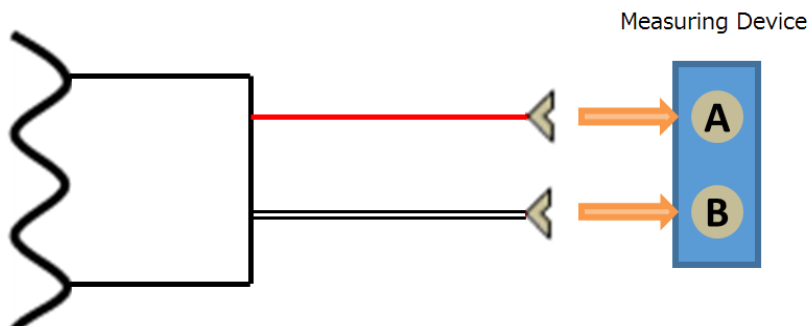

Figure 4-17. MT-052-T Connection Example

NOTE: The connections may differ depending on the measurement device used. Follow the instructions provided by the manufacturer.

5. Maintenance & Troubleshooting

5-1. Maintenance

To maintain accurate measurement and protect from degradation, it is recommended to check and do the following once every month:

1. Check Ventilation Condition of Radiation Shield

Check the ventilation condition of the radiation shield; keep the radiation shield free from leaves, insects or any other objects that will block a free airflow. The temperature tends to be measured higher when there is no air movement.

2. Clean Temperature Sensor

Regularly check the temperature sensor probe and clean it when necessary. Soiling may lead to inaccurate temperature measurements.

3. Check Cable Condition

Regularly check the cable condition for cracks and wire connections. It is recommended to replace the cable and temperature sensor when any irregularities are observed.

5-2. Troubleshooting

Check the following items in case of trouble with the sensor. If any questions should remain, contact EKO for further technical support.

Table 5-1. Troubleshooting

Failure	Action
The measured temperature value tends to be higher.	Check whether the specified measurement current is over 1mA. However this specification may be different depending on the specified current of the measuring device used. The Pt100 temperature may become higher due to heat when the specified current is over 1mA.
	Air ventilation may be insufficient. Use MT-052-A/T in a well-ventilated environment. Temperature is measured higher than actual temperature when the temperature sensor is in an unventilated environment. The difference between the measured Pt100 temperature sensor and the actual temperature becomes much smaller when it is well ventilated. (See Appendix A-1)
Measurement values are unstable.	Check the wiring; make sure the cables are connected appropriately. If some of the wires are disconnected, the resistance cannot be measured correctly.
There are no measurement value outputs	Check for any disconnection in output cable.

6. Specification

6-1. Specification

Table 6-1. Radiation Shield Specifications

Characteristics		Details
Weight		1.2kg (with standard 10m cable Temperature Sensor)
Operating Temperature Range		-40 to +60°C
Radiation Error		See Appendix A-1. Wind speed and Sun Elevation Effects
Radiation Shield Specification		
Size	Overall Shield	Φ130mm x 260mm
	Allowable Sensor Size	φ10mm x120mm
	Diameter Size of the object to be Mounted	φ40 to 60mm
Material		UV stabilized white thermoplastic plates

Table 6-2. Temperature Sensor Specification

MT-010 Temperature Sensor Specification	
Sensor	Pt100 Class A sheath type RTD, 4-wire type
Accuracy	JIS C 1604-2013, Class A or IEC 60751 Class A ±0.15°C+0.002 t t : Absolute value of temperature
Specified Current	1mA
Probe Material	Stainless Steel
Size	Φ4.8mm x 100mm (Sheath part)
MT-010-T Temperature Sensor Specification	
Sensor	T-type (Copper-Constantan)
Acceptable Class	JIS Class1
Temperature Measuring Junction	Non-mounted type
Compensating Lead	Shield inside vinyl coating
Temperature Measuring Range	0 to 60°C
Material	Stainless Steel
Dimension	Φ4.8mm x 100mm (Sheath part)

6-2. Dimensions

1. Radiation Shield Dimension

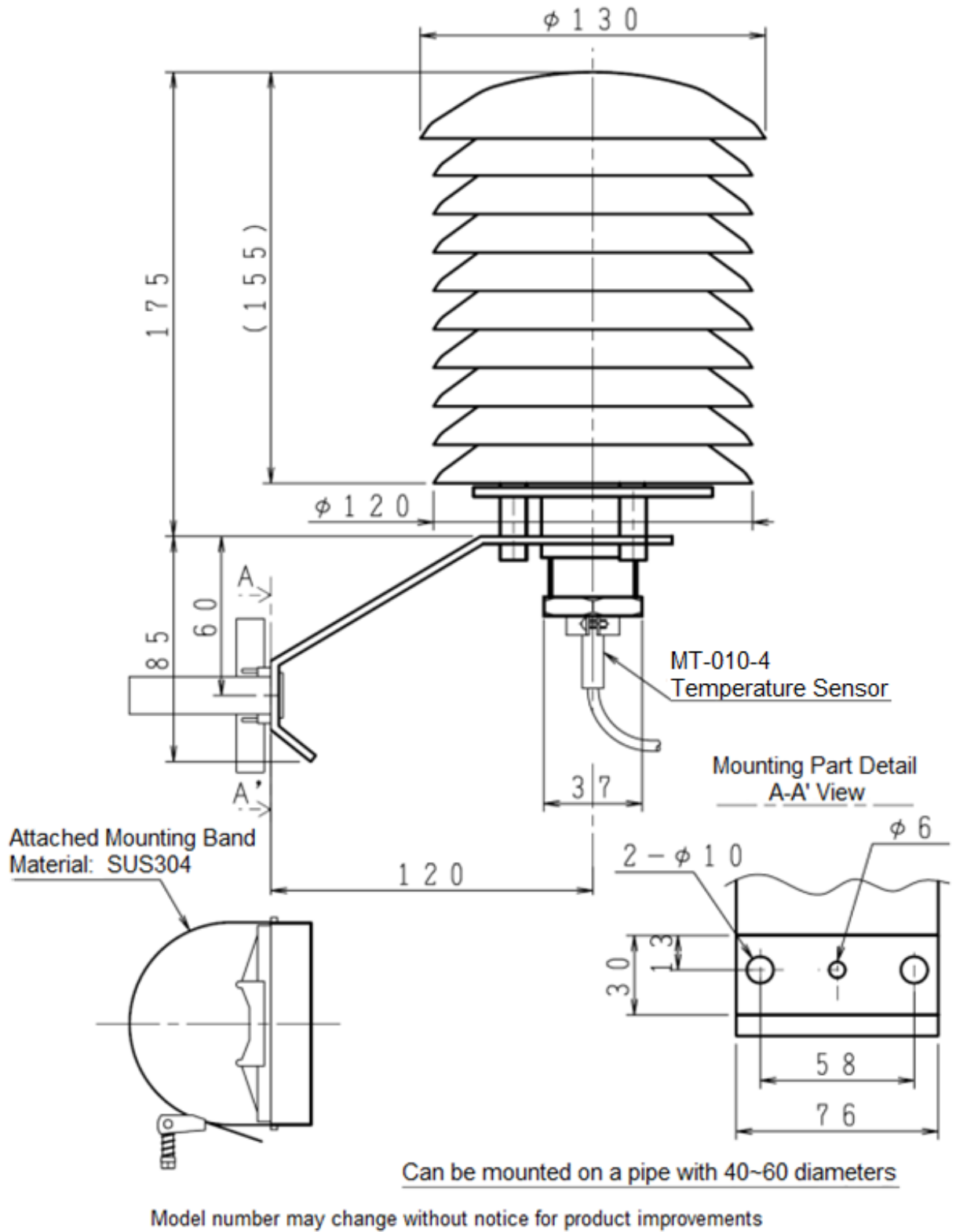

Figure 6-1. Radiation Shield Dimensions

2. Temperature Sensor: MT-010

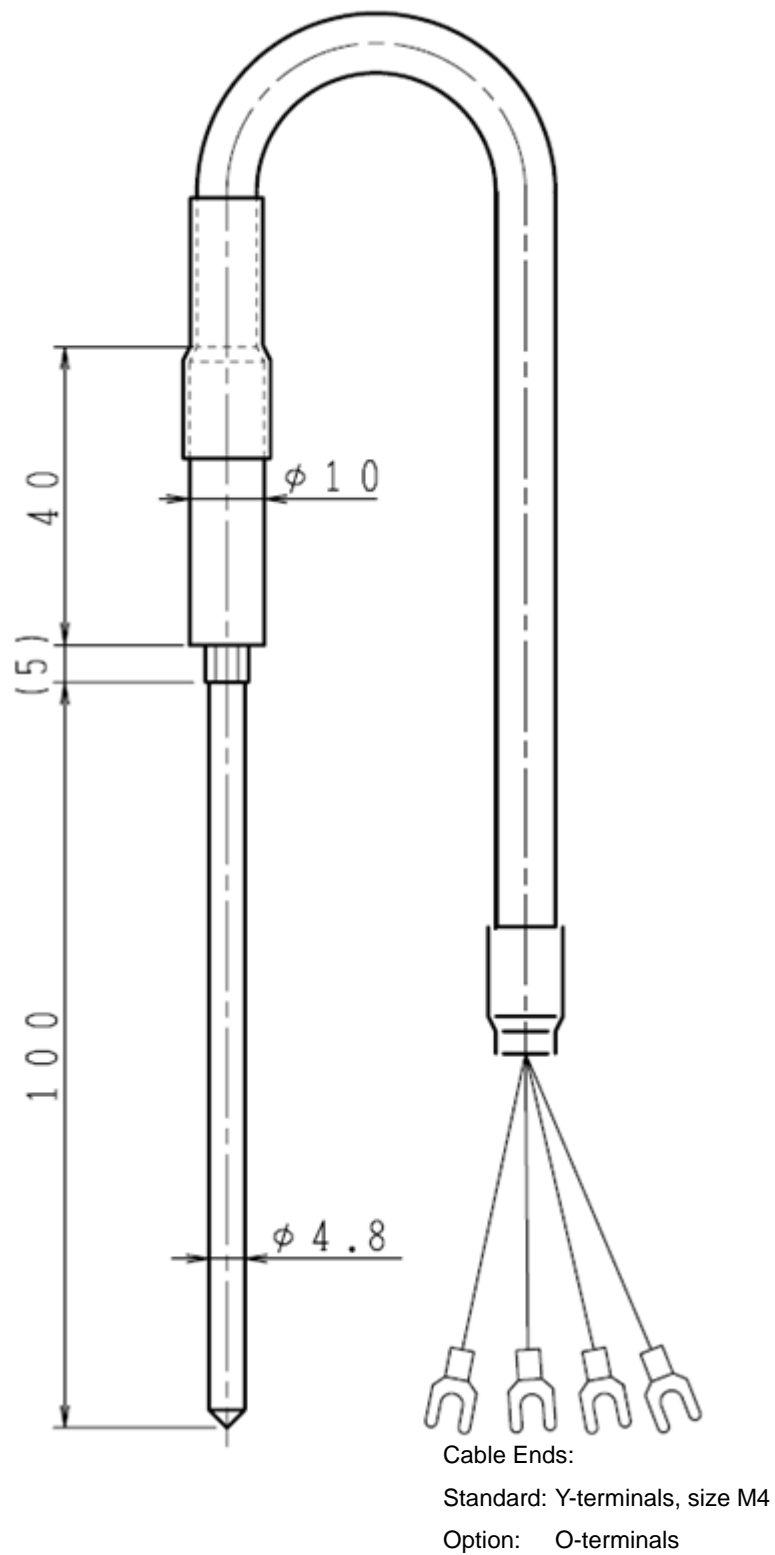
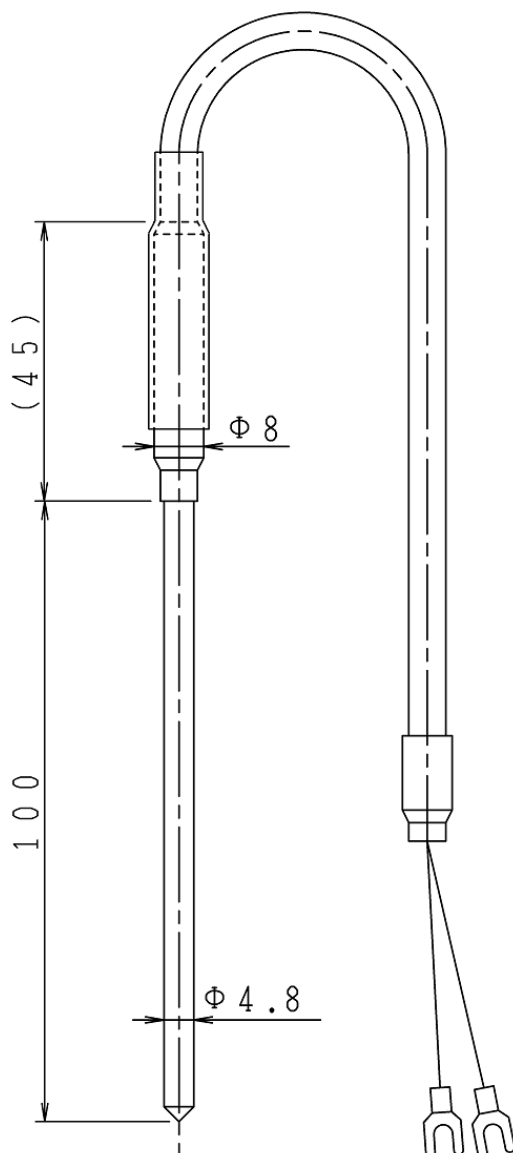

Figure 6-2. MT-010 Temperature Sensor Dimensions

3. Temperature Sensor: MT-010-T



Cable Ends:
 Standard: Y-terminals, size M4
 Option: O-terminals

Figure 6-3. MT-010-T Temperature Sensor Dimensions

6-3. Accessories List

Table 6-3. Accessories List

Option Items	Remarks
Temperature Sensor MT-010	Cable Length: 20m, 30m, 50m
Temperature Sensor MT-010-T	Cable Length: 20m, 30m, 50m

APPENDIX

A-1. Wind Speed & Sun Elevation Effects

Below graph Figure A-1 shows the effects of solar radiation and wind on the temperature measured by the temperature sensor inside radiation shield, and how it creates differences in temperature.

The Sun Elevation 90° stated in the graph represents the zenith.

Radiation error at 70° sun elevation and 1080W/m² solar radiation:

- 0.4°C RMS at 3m/s wind speed
- 0.7°C RMS at 2m/s wind speed
- 1.5°C RMS at 1m/s wind speed

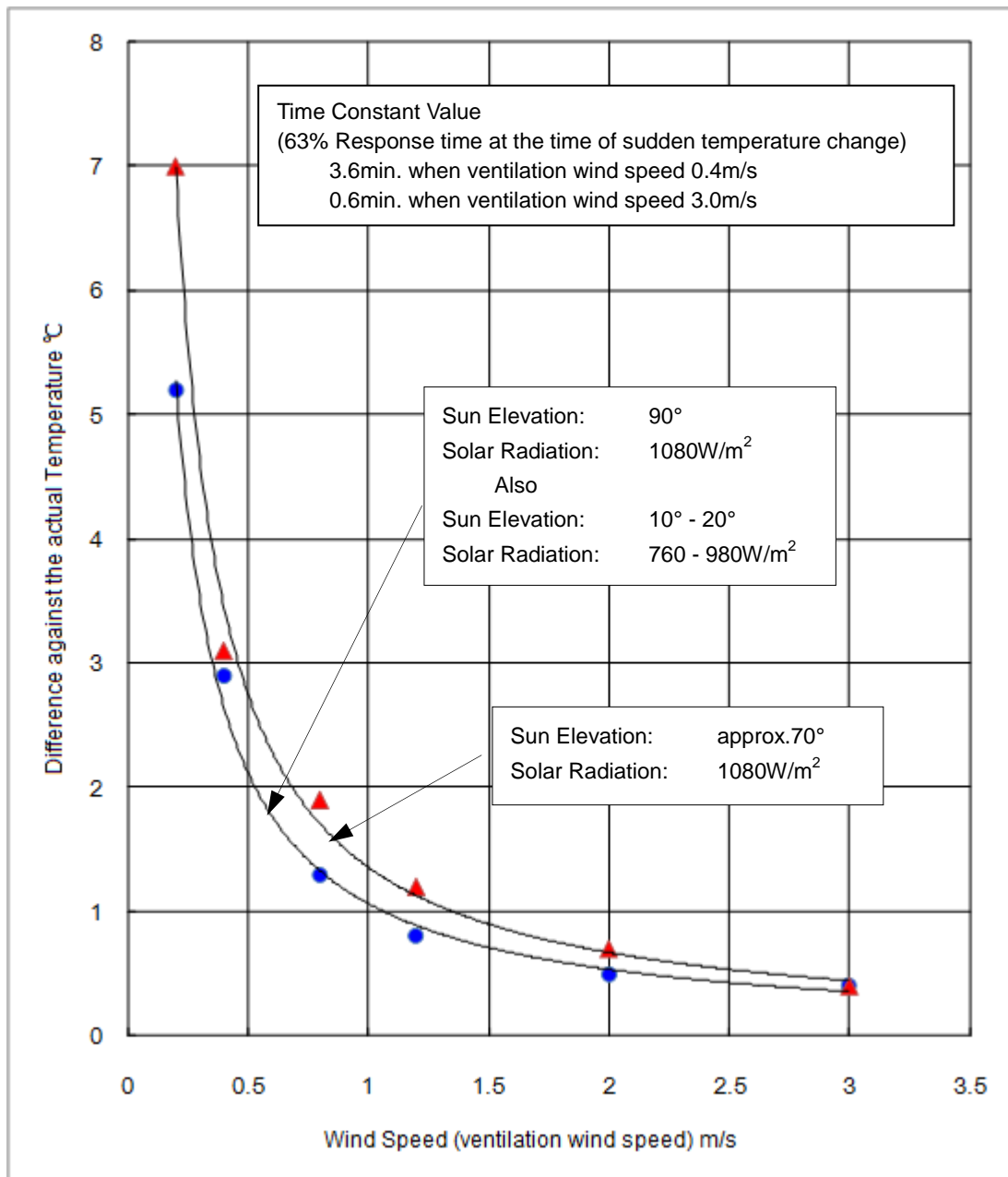

Figure A-1. Wind speed and Sun Elevation Effects on Temperature inside MT-052-A

A-2. Conversion Table for Pt100 Temp. Sensor

Conversion table for Pt100 temperature resistance sensor (Pt100 A Class)

Table A-2. Conversion Table for Pt100 Temperature Sensor

T [°C]	R [Ω]	T [°C]	R [Ω]	T [°C]	R [Ω]
-30	88.2	0	100.0	30	111.7
-29	88.6	1	100.4	31	112.1
-28	89.0	2	100.8	32	112.4
-27	89.4	3	101.2	33	112.8
-26	89.8	4	101.6	34	113.2
-25	90.2	5	102.0	35	113.6
-24	90.6	6	102.3	36	114.0
-23	91.0	7	102.7	37	114.4
-22	91.4	8	103.1	38	114.8
-21	91.8	9	103.5	39	115.2
-20	92.2	10	103.9	40	115.5
-19	92.6	11	104.3	41	115.9
-18	92.9	12	104.7	42	116.3
-17	93.3	13	105.1	43	116.7
-16	93.7	14	105.5	44	117.1
-15	94.1	15	105.8	45	117.5
-14	94.5	16	106.2	46	117.9
-13	94.9	17	106.6	47	118.2
-12	95.3	18	107.0	48	118.6
-11	95.7	19	107.4	49	119.0
-10	96.1	20	107.8	50	119.4
-9	96.5	21	108.2	51	119.8
-8	96.9	22	108.6	52	120.2
-7	97.3	23	109.0	53	120.6
-6	97.7	24	109.3	54	120.9
-5	98.0	25	109.7	55	121.3
-4	98.4	26	110.1	56	121.7
-3	98.8	27	110.5	57	122.1
-2	99.2	28	110.9	58	122.5
-1	99.6	29	111.3	59	122.9

Pt100 A Class: Complies to JIS C 1604 -2013 and IEC 60751



EKO Asia, Oceania

1-21-8 Hatagaya,
Shibuya-ku, Tokyo
151-0072 Japan
P. +81.3.3469.6711
F. +81.3.3469.6719
info@eko.co.jp
www.eko.co.jp

EKO North America

95 South Market Street,
Suite 300, San Jose,
CA 95113, USA
P. +1-408-977-7751
F. +1-408-977-7741
info@eko-usa.com
www.eko-usa.com

**EKO Europe,
Middle East, Africa,
South America**

Lulofsstraat 55, Unit 32,
2521 AL, Den Haag,
The Netherlands
P. +31 (0)70 3050117
F. +31 (0)70 3840607
info@eko-eu.com
www.eko-eu.com