



USER MANUAL

15189

Precipitation Sensor



Warranty

Please note the loss of warranty and non-liability by unauthorized manipulation of the system. You need a written permission of the LAMBRECHT meteo GmbH for changes of system components. These activities must be operated by a qualified technician.

The warranty does not cover:

1. Mechanical damages caused by external impacts (e. g. icefall, rockfall, vandalism).
2. Impacts or damages caused by over-voltages or electromagnetic fields which are beyond the standards and specifications in the technical data.
3. Damages caused by improper handling, e. g. by wrong tools, incorrect installation, incorrect electrical installation (false polarity) etc.
4. Damages which are caused by using the device beyond the specified operation conditions.

Safety instructions

This system is designed according to the state-of-the-art accepted safety regulations. However, please note the following rules:

1. Before setting into operation, please read all appropriate manuals!
2. Please take notice of internal and state-specific guidelines and/or rules for the prevention of accidents (e.g. the professional association). If necessary ask your responsible safety representative.
3. Use the system according to the manual's regulations only.
4. Always leave the manual at hand at the place of work of the system.
5. Use the system in technically correct conditions only! You have to eliminate influences immediately which impair the security.
6. Please note the loss of warranty and non-liability by unauthorized manipulation of the system. You need a written permission of the LAMBRECHT meteo GmbH for changes of system components. These activities must be operated by a qualified technician.
7. Prevent the ingress of liquids into the devices without permission.

Features

- Precipitation sensor for automatic weather stations
- Exchangeable, weighing tipping bucket system according to Joss-Tognini
- 2 cm³ (2 g water) tipping bucket for precise precipitation measuring in regions with normal rain falls
- 4 cm³ (4 g water) tipping bucket for precise precipitation measuring in regions with heavy rain falls/ tropical rain
- Connectable to external data logger
- Winter-fit model 15189 H with electronically controlled 2-circuit heating
- Weatherproof materials (anodized aluminium, stainless steel) guarantee a long durability
- Funnel according to the WMO Standard No. 8



Function

The weighing precipitation sensor 15189 works with a low-friction mounted tipping bucket according to Joss-Tognini. Errors that normally occur due to incomplete draining because of surface tension are automatically compensated by the specific form of the tipping bucket. The tipping bucket can hold 2 cm³ (2 g) resp. 4 cm³ (4 g) of water. The collecting surface of 200 cm² (WMO standard) means that one bucket charge is equivalent to a precipitation rate of 0.1 mm resp. 0.2 mm per square meter. If the bucket is tipped, the reed contact that is integrated in the sensor will be closed. This pulse output can be electrically scanned, remotely transmitted and recorded. A bounce-free signal can be achieved by using the corresponding electrical connection. Otherwise the signal of the reed contact can be used directly, not bounce-free, if this function will be carried out by an appropriate data logger (e. g. Ser[LOG]).

The precipitation sensor 15189 is mounted on a mast, whose outer diameter is 60 mm. For application in snowfall regions the heater equipped model 15189 H ensures all year round measurement. Two separate controlled heating circuits with lowest hysteresis are providing an optimal temperature at which snowing up of the sensor will normally be prevented and evaporation from the heated surfaces will be minimized. The precipitation sensor 15189 is made of weather-resistant aluminium and stainless steel. This ensures a long durability. These high-quality precipitation sensors comply with the regulations WMO.

Dimensional drawing

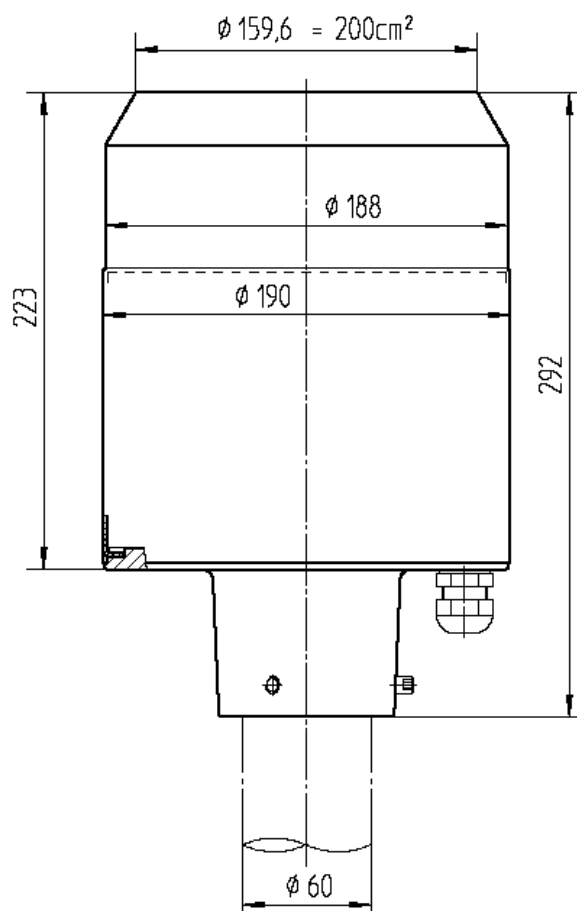

Installation

MOUNTING OF THE PRECIPITATION SENSOR

The precipitation sensor 15189 must be mounted on a tube or pole with an outside diameter of 60 mm. A metallic extension tube with a minimum length of 100 mm is recommended, if a wooden pole is used. For easy adjustment place a spirit-level on the upper measuring edge.



Attention! Do not damage the measuring edge!

Place the precipitation sensor 15189 on the end of the pole until it fits in.

By using the provided allen key (4 mm), tighten the screws in the mounting pedestal evenly. Adjust the upper measurement edge to an exact horizontal position. By doing this, the tipping bucket will automatically be positioned vertically inside the device and will work symmetrically.

DISMOUNTING OF THE PROTECTIVE COVERING

Loosening the screw with the provided 3 mm allen key until the protective covering can be turned right to the stop position and take off upward then.

ASSEMBLY OF THE TIPPING BUCKET



To avoid damage to the tipping bucket during transport, it is separately packed and should be inserted in the precipitation sensor (15189) on site only after mounting the gauge on the mast. For the assembly first you must remove the protective covering.



Attention! When fitting the tipping bucket, proceed with utmost caution so that the sharp edges of the tipping bucket are not damaged and the middle wall is not bent!

During operation the tipping bucket lies on the precision bucket bearings. To reduce the friction the bearings are made of abrasion-resistant delrin. The mounted tipping bucket is secured against eventual changes of position by means of two plates.

To insert the tipping bucket, first the relocatable locking plate **C** must be pushed back. Now insert the tipping bucket **F**. Make sure that the magnet **E** attached at the middle wall of the tipping bucket rests under the capsule with the embedded reed contact **D**. Finally the tipping bucket must be secured by pushing back the relocatable locking plate **C**.



MOUNTING OF THE PROTECTIVE COVERING

When mounting the protective covering, please make sure that the sign "close <---> open" (close <-> to) is positioned above the fixing screw. Especially when using the heated version you have to pay attention to this step. This avoids that the cable of the protective covering heating may block the tipping bucket.

! **Attention!** In order to protect the tipping bucket the dirt spiral must be inserted in the collecting funnel.

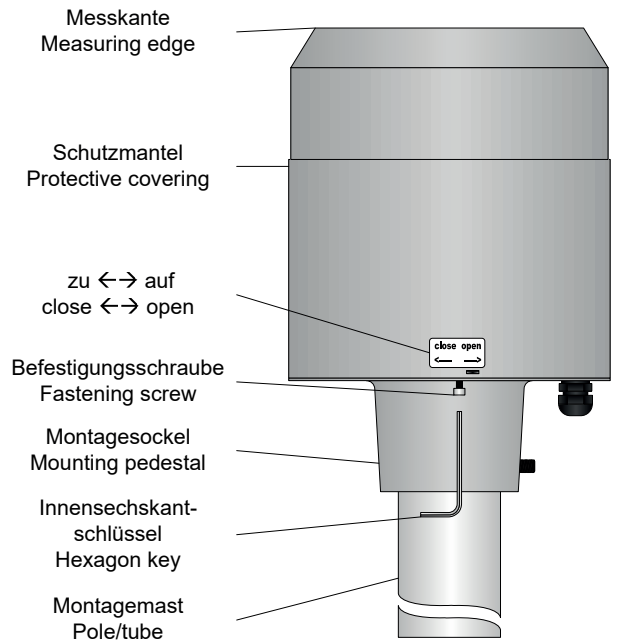
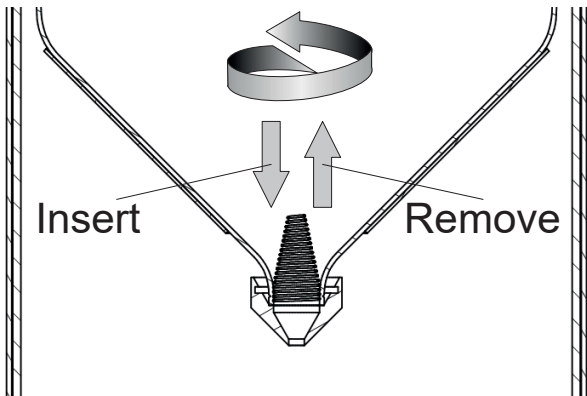

- A: Tipping bucket bearings
- B: Fixed locking plate
- C: Relocatable locking plate
- D: Reed contact
- E: Magnet (here shown through inclination of the bucket)
- F: Tipping bucket

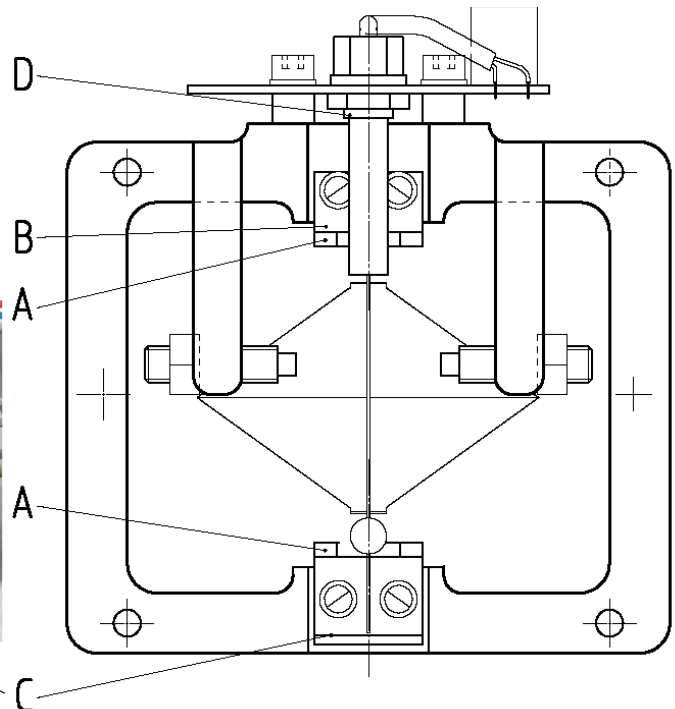
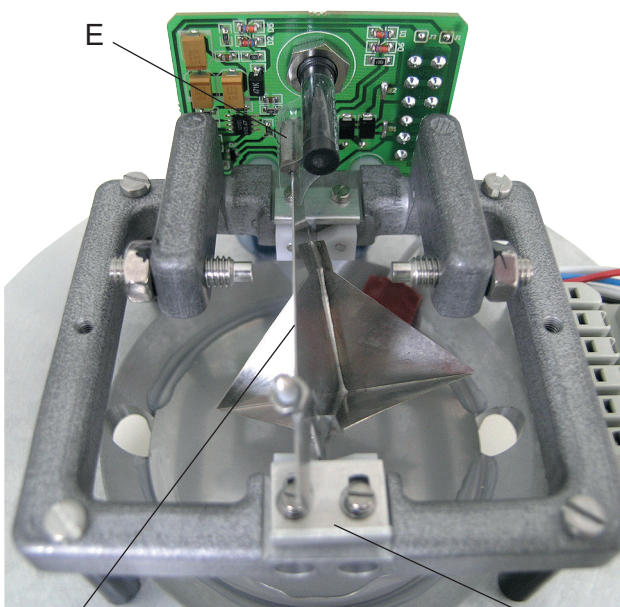

Electrical connection

The sensor will be connected to the cable by leading the cable through the conduit gland to the connector inside the sensor housing. Recommended cable type:

2 (4) x AWG 20 CUL sw;
diameter approx. 5.1 mm

The cable should not be longer than 11 m.



When the cable is transferred inside the ground it is recommended to protect the cable with a protecting plastic tube.

USE OF THE BOUNCE-FREE OUTPUT SIGNAL

The usual circuit of the precipitation sensors is suitable for connection to data loggers without an own bounce-free impulse input. For this application the clamps 3 and 4 are used.



Make sure, that the current supply for the precipitation sensor with usual circuit is not less than 100 μ A (see also technical data).

USE OF THE DIRECT OUTPUT SIGNAL

This circuit variant of the precipitation sensors is suitable for connection to data loggers with a bounce-free impulse input. For this application the clamps 1 and 6 are used. In this case the current supply of the electronics with 100 μ A is not necessary. The LAMBRECHT meteo data logger TROPOS is equipped with such a bounce-free input. Thus the direct output signal of the reed contact is used. An additional benefit is a low-current effect.

VERSION WITH HEATING 15189 H

Version i. e. with a controlled 2-circuit heating for collecting funnel and drain pipe.

ELECTRICAL CONNECTION OF THE HEATING

For the connection of the heating a 4-core cable is required, which has to apply and connect to the power supply unit according to the *connecting diagrams* with heating.

The **function of the heating elements** can be tested also at ambient temperatures above the control temperature of the solid-state thermostat. For this simple test a regular magnet has to be held close to the blue housing of the switching circuit. When reaching a surface temperature of approximately 50 °C the current will be switched off.

Both blue thermostat modules are fitted internally on the funnel surface as well as on the bottom of the housing. The operational conditions will be indicated with colored light-emitting diodes (LED) on the thermostatic module:

green: supply voltage

red: heating on

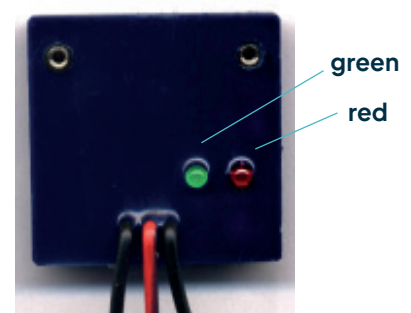

Initial operation

If the sensor system has been completely mounted and electrically assembled, the sensor will be ready for operation. An operational check has to be performed.

Maintenance and operational check

The precipitation sensor is nearly maintenance-free. The sensor should be checked and cleaned periodically in order to guarantee its proper operation, because dirt accumulation may cause errors of measurement. The time interval of cleaning depends on the local conditions.

The **operational check** of the sensor may be performed by the use of artificial precipitation. The volume of a 200 cm³ resp. 400 cm³ (by 4 cm³ buckets) test container of water must be piped into the collecting funnel through a nozzle in such a way that the drops fall into the funnel beside the outlet. The nozzle of the test container (approx. diameter 0.6 mm) should be adjusted to allow a complete water run out into the funnel within 10 to 12 minutes. After the artificial precipitation has gone through, 100 ± 2 bucket tipplings should have counted.

Rinse the sensor thoroughly for cleaning. Clinging particles of dirt in the collecting funnel or outlet pipe may be removed with a piece of wood. If unsatisfying measurement results occur after this cleaning procedure, the tipping bucket should be disassembled for cleaning.



Absolute care must be taken not to damage the tipping bucket!

The dismantled tipping bucket can be cleaned by placing it in warm water with some scouring material and by carefully scraping off unwanted dirt by using a small piece of wood.

Disposal

LAMBRECHT meteo GmbH is listed and registered at the Stiftung Elektro-Altgeräte Register under:

WEEE-Reg.-Nr. DE 45445814

In the category of monitoring and control instruments, device type: "Monitoring and control instruments for exclusively commercial use".

Within the EU



The device has to be disposed according to the European Directives 2002/96/EC and 2003/108/EC (Waste Electrical and Electronic Equipment). Do not dispose the old device in the household waste! For an environmentally friendly recycling and disposal of your old device, contact a certified disposal company for electronic waste.

Outside the EU

Please follow the regulations in your country regarding the appropriate disposal of waste electronic equipment.

Connecting diagrams

with heating

Niederschlags-Sensor
rain gauge
00.15189.402000 (2ccm)
00.15189.404000 (4ccm)

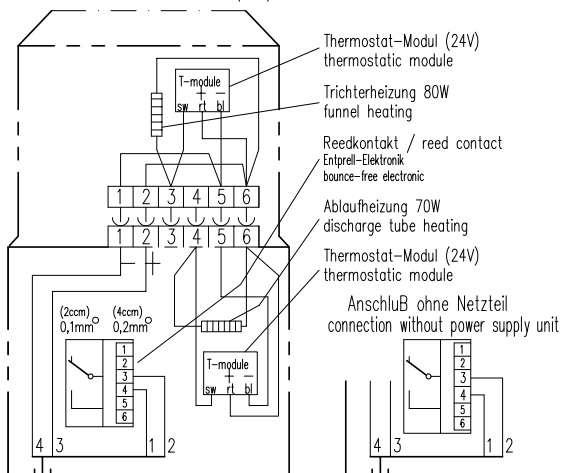

Netzteile / power supply unit
00.14966.200000

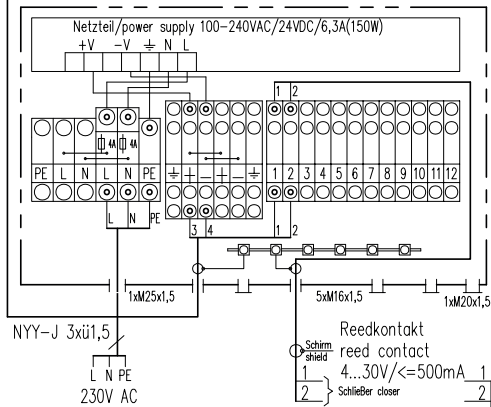

Zweileiteranschluß
TWO-WIRE-INTERFACE

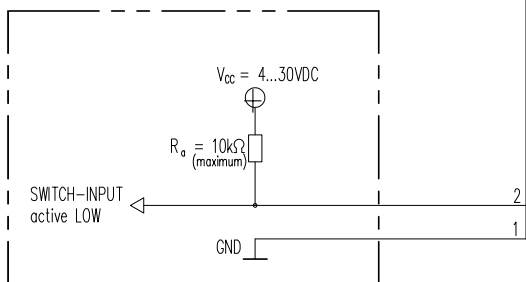

without heating

Niederschlags-Sensor
rain gauge
00.15189.002000 (2ccm)
00.15189.004000 (4ccm)

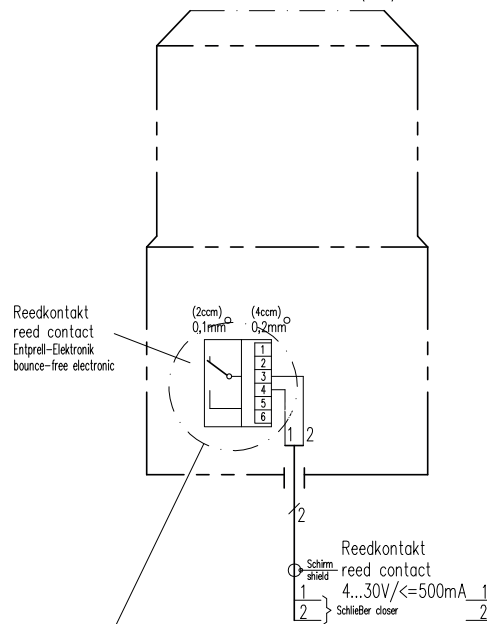

- oben top
- 1 Reedkontakt, direkt / reed contact direct
 - 2 6 for factory use + TROPOS
 - 3 Reedkontakt / reed contact
 - 4 entprellt / bounce-free
 - 5 2 for factory use
 - 6 5 for factory use

AWG-cable colorcode	
1	blk-black
2	brn-brown
3	red-red
4	ora-orange

Zweileiteranschluß
TWO-WIRE-INTERFACE

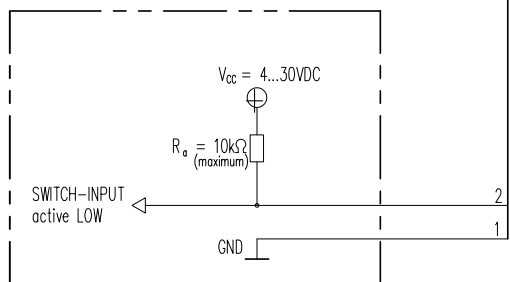

Technical data

	15189 Version with 2 cm ³ bucket, unheated
ID	00.15189.002000
Measuring principle	Weighing tipping bucket designed acc. to Joss-Tognini
Measuring range	2 cm ³ (2 g water); volume of bucket 0...8 mm/min
Resolution	0.1 mm
Accuracy	± 2 % with intensity correction *)
Range of application	0...+70 °C measuring
Pulse output	Reed contact; reverse polarity protected; debounced signal
Current consumption	Max. 100 µA; typically 50 µA
Supply voltage	4...30 VDC
Switching load	Max. 30 VDC/0.5 A
Dimensions	See dimensional drawing
Mounting Ø	60 mm
Material	Enclosure: Anodized aluminium, painted Funnel: Anodized aluminum Device base component: Die-cast aluminum, painted Tipping bucket: Stainless steel, brazed
Weight	Approx. 3.0 kg
Standards	WMO-No. 8; VDI 3786 Sheet 7; EN 50081/82; VDE 0100
	15189 W4 Version with 4 cm ³ bucket, unheated Data as 00.15189.002000, but for high rainfall rates
ID	00.15189.004000
Measuring range	4 cm ³ (4 g water); volume of bucket 0...16 mm/min
Resolution	0.2 mm
	15189 H Version with 2 cm ³ bucket, heated Data as 00.15189.002000, but with controlled 2-circuit heating
ID	00.15189.402000
Heating data	Electronically controlled; 2 heating circuits
Accuracy	4 °C ± 2 °C control temperature in the range of -20...+4 °C
Heating capacity	80 W (funnel); 70 W (outlet/ tipping bucket)
Supply voltage	24 VDC/150 W
Range of application	-20...+70 °C (no icing, no snowdrift)
	15189 H W4 Version with 4 cm ³ bucket, heated Data as 00.15189.004000, but with controlled 2-circuit heating (as 15189 H)
ID	00.15189.404000



Accessories

ID	General accessories
00.15180.400000	Stainless steel mast for concrete/earth foundation
00.15180.800050	Stainless steel mast for concrete foundation (with base plate)
32.15180.023020	Bird defense ring
33.15180.049000	Dirt pan (spare part)
32.15188.060090	Connection cable sensor/ data acquisition; 2-core; L=7 m
ID	Accessories for versions with heating (H versions)
00.14966.200000	Power supply unit
32.15188.061020	Connecting cable sensor/ power supply unit; for mast mounting; 4-core; L ≈ 1 m
32.14622.220000	Holder for power supply unit on the mast
32.15188.061090	Connection cable sensor/ power supply unit; 4-core; L = 7 m

*) The intensity compensation is not done in the sensor but in the data logger, e.g. Ser[LOG], met[LOG].